

ELECTROMAGNETIC WAVE PROPAGATION AND SOURCE RADIATION  
IN  
SPACE-TIME PERIODIC MEDIA

by

Charles Elachi

Antenna Laboratory

Technical Report No. 61

This research was supported by the  
U.S. Air Force through the Air Force  
Office of Scientific Research/AFSC  
under Grant No. AFOSR-70-1935

Conditions of Reproduction

Reproduction, translation, publication,  
use, and disposal in whole or in part  
by or for the United States Government  
is permitted.

California Institute of Technology  
Pasadena, California

November 1971

#### ACKNOWLEDGMENTS

I would like to express my deep appreciation to Professor Charles H. Papas for his guidance, inspiration and encouragement during the course of this work and throughout my studies at the California Institute of Technology.

I acknowledge with thanks the efforts of Mrs. Ruth Stratton in typing the manuscript.

This work is dedicated to my dear parents.

ABSTRACT

The electromagnetic wave equations for the fields, potentials and Hertz vectors are derived and a Lorentz gauge is given for space-time dependent media. Electromagnetic wave propagation, electric and magnetic dipole radiation, and Cerenkov and transition radiation in sinusoidally space-time periodic dielectric, plasma and uniaxial plasma are studied and numerous radiation patterns are given. A special radiation effect in the uniaxial plasma is investigated. Finally the study is extended to general space-time periodic media (i.e.,  $\epsilon = \epsilon_0 \epsilon_r [1 + \epsilon_1 f(Kz - \Omega t)]$  where  $f(\xi)$  is a periodic function).

TABLE OF CONTENTS

I. Introduction	1
II. Space-Time Periodic Dielectric	3
A. Wave equations	3
B. General solution	5
C. Reflection and transmission: half space	21
D. Guided waves	31
E. Reflection and transmission: slab	32
F. Dipole radiation	40
G. Different approach	61
III. Space-Time Periodic Isotropic Plasma	68
A. Infinite and half space	68
B. Dipole radiation	75
IV. Space-Time Periodic Uniaxial Media	80
A. Wave in infinite and half space	81
B. Dipole radiation	92
V. Cerenkov Radiation in Space-Time Periodic Media	101
A. Fields	101
B. Radiation and Spectrum	108
C. Transition radiation in plasma	115
VI. Waves in General Space-Time Periodic Media	118
A. Dielectric	118
B. Plasma	122

VII. Conclusion	124
Appendix A: Potentials, Lorentz Gauge and Hertz Vectors in Space-Time Dependent Media	125
Appendix B: Amplitude Ratios	130
Appendix C: Steepest Descent Method	132
Appendix D: Caustics	133
References	135

## I. INTRODUCTION

Considerable interest has recently been stimulated by phenomena that involve the interaction between two waves in the presence of liquids, solids or plasma, including such applications as diffraction of light by ultrasonic waves [1], parametric processes in nonlinear media [2], optical visualization of sonic waves [3,4], Bragg scattering in plasma [5], and others. These processes usually involve a stronger wave (of the elastic, electromagnetic, or other type) that produces a space-time periodic modulation of the properties of a medium which in turn causes a diffraction of the weaker wave (usually of the electromagnetic type).

The configuration which is customarily selected to represent the two-wave interactions expresses the periodic modulation caused by the strong wave as a traveling wave variation of the permittivity along one particular direction in the medium (i.e.,  $\epsilon(z,t) = \epsilon_0 \epsilon_r [1 + \epsilon_1 f(Kz - \Omega t)]$  where  $f(\xi)$  is a periodic function); this allows linearization of the problem. Two limiting cases are also of great interest: periodically time-dependent media (i.e.,  $K = 0$ ) and periodically stratified media (i.e.,  $\Omega = 0$ ).

Plane waves in periodically time-dependent media were studied by Holberg and Kunz [6]. Plane wave propagation, dipole radiation, Cerenkov and transition radiation in sinusoidally stratified media were extensively investigated in the last decade by numerous authors [7-14]. For sinusoidally space-time periodic media, only the plane wave and guided wave propagation problems in dielectric and

isotropic plasma were studied [15-20].

In our present work, the problem of electromagnetic waves in sinusoidally space-time periodic media is formulated in a compact form such that the basic results and diagrams apply, with minor changes, to different problems (plane wave propagation, electric and magnetic dipole radiation, and Cerenkov and transition radiation), and to different media (dielectric, plasma, anisotropic and uniaxial media). Our method is then extended to the generally space-time periodic media and all the analytic results obtained in the sinusoidal case are found to be valid, with slight modifications, in the general periodic case.

A method using the Hertz vectors is also investigated, the Hertz vectors wave equations are derived, and a new Lorentz gauge is given for space-time dependent media.

In most of our study no limit on the modulation amplitude  $\epsilon_1$  is imposed (except that  $\epsilon > 0$  for the dielectric and  $N > 0$  for the plasma density), and the analytic solutions are exact (approximations are used only in the numerical computations).

## II. SPACE-TIME PERIODIC DIELECTRIC

The medium constants are taken as

$$\mu = \mu_0 = \text{free space magnetic permeability}$$

$$\epsilon = \epsilon(z,t) = \epsilon_0 \epsilon_r [1 + \epsilon_1 \cos(Kz - \Omega t)]$$

where  $\epsilon_0 =$  free space electric permittivity

$\epsilon_r =$  relative permittivity of the undisturbed dielectric

$\epsilon_1 =$  amplitude of the relative permittivity change due to the disturbance

The disturbance is a plane wave propagating in the z direction with a velocity  $v_d = \Omega/K$

### A. Wave Equations

#### 1. Field equations:

Maxwell's equations for the current-free medium are:

$$\nabla \times \underline{E} = -\mu_0 \frac{\partial \underline{H}}{\partial t} \quad (2A.1)$$

$$\nabla \times \underline{H} = \frac{\partial}{\partial t} [\epsilon(z,t)\underline{E}] \quad (2A.2)$$

$$\nabla \cdot \underline{H} = 0 \quad (2A.3)$$

$$\nabla \cdot [\epsilon(z,t)\underline{E}] = 0 \quad (2A.4)$$

This set of equations gives the wave equation in a space-time dependent media:

$$\nabla^2 \underline{E} = \mu_0 \frac{\partial^2}{\partial t^2} [\epsilon(z,t)\underline{E}] + \nabla \nabla \cdot \underline{E} \quad (2A.5)$$

$$\nabla^2 \underline{H} = \mu_0 \frac{\partial}{\partial t} [\epsilon(z,t) \frac{\partial \underline{H}}{\partial t}] + \frac{\partial}{\partial t} [\underline{E} \times \nabla \epsilon(z,t)] \quad (2A.6)$$



The electromagnetic field can be subdivided into a T.E. field (i.e., transverse electric where  $\underline{E} = E \underline{e}_y$  and  $\underline{H} = H_x \underline{e}_x + H_z \underline{e}_z$ ), and a T.M. field (i.e., transverse magnetic where  $\underline{H} = H \underline{e}_y$  and  $\underline{E} = E_x \underline{e}_x + E_z \underline{e}_z$ ) relative to the z-direction (Fig. 1). For the T.E. field the vector  $\underline{E}$  is normal to  $\underline{\nabla}\epsilon(z,t)$ , then equation 2A.4 becomes

$$\nabla \cdot [\epsilon(z,t)\underline{E}] = \epsilon(z,t)\nabla \cdot \underline{E} + \underline{E} \cdot \underline{\nabla}\epsilon(z,t) = \epsilon(z,t)\nabla \cdot \underline{E} = 0$$

and the wave equation reduces to

$$\nabla^2 \underline{E} - \mu_0 \frac{\partial^2}{\partial t^2} (\epsilon \underline{E}) = 0 \quad (2A.7)$$

where  $\underline{E} = E \underline{e}_y$ . For the T.M. field, no such simplification is possible.

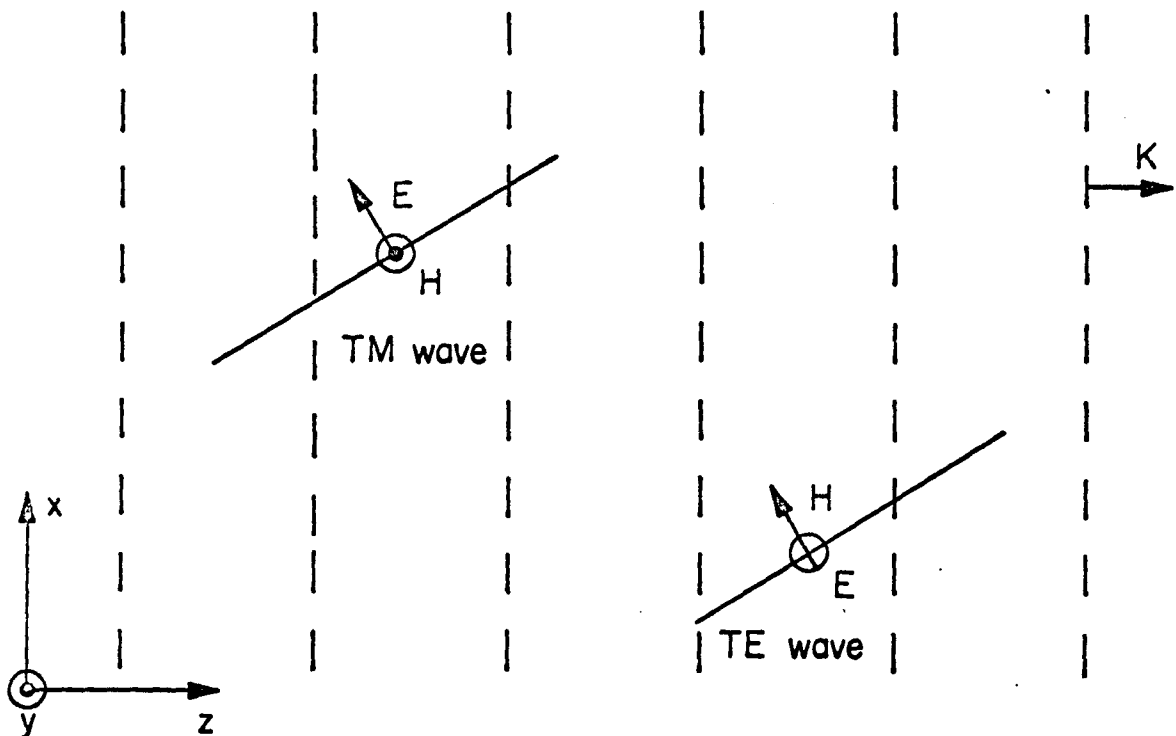

Fig. 1. TE and TM Fields

## 2. Hertz vectors

The electromagnetic field can be described by the electric Hertz vector  $\underline{\Pi}$ , and magnetic Hertz vector  $\underline{M}$  which are defined by (see Appendix A):

$$\underline{E} = -\frac{1}{\epsilon} \nabla \times \nabla \times \underline{\Pi} + \nabla \times \frac{\partial \underline{M}}{\partial t} \quad (2A.8)$$

$$\underline{H} = -\frac{1}{\mu_0} \nabla \times \nabla \times \underline{M} - \nabla \times \frac{\partial \underline{\Pi}}{\partial t} \quad (2A.9)$$

The Hertz vectors have the properties that, in our problem, their wave equations are scalar equations. In fact, as the vector currents considered in this study are parallel to the z-axis, the e.m. field can be determined completely from the z components of the two Hertz vectors. Outside the source volume, we get:

$$\underline{\Pi} = \Pi \underline{e}_z \quad \underline{M} = M \underline{e}_z \quad (2A.10)$$

$$\nabla_2^2 \Pi + \epsilon \frac{\partial}{\partial z} \left( \frac{1}{\epsilon} \frac{\partial \Pi}{\partial z} \right) - \mu_0 \epsilon \frac{\partial^2 \Pi}{\partial t^2} = 0 \quad (2A.11)$$

$$\nabla^2 M - \mu_0 \frac{\partial}{\partial t} \left( \epsilon \frac{\partial M}{\partial t} \right) = 0 \quad (2A.12)$$

where  $\nabla_2^2 = \nabla^2 - \frac{\partial^2}{\partial z^2}$ . See Appendix A for the detailed computation.

### B. General Solution

#### 1. Transverse electric waves:

- a. Dispersion equation and wave vector diagram.

The electric field  $\underline{E} = E(x,z,t)\underline{e}_y$  is a solution of the equation

$$\nabla^2 E - \mu_0 \frac{\partial^2}{\partial t^2} (\epsilon E) = 0 \quad (2B.1)$$

Using Floquet's theorem in conjunction with the principle of superposition, the solution for the electric field can be written

$$E(x, z, t) = e^{i\delta x + i(\kappa z - \omega t)} \sum_{n=-\infty}^{n=+\infty} E_n e^{in(Kz - \Omega t)}$$

or

$$E(x, z, t) = \sum_{n=-\infty}^{+\infty} E_n e^{i\delta x + i(\kappa + nK)z - i(\omega + n\Omega)t} \quad (2B.2)$$

where:  $E_n$  = amplitude of the harmonics which are generated by the interaction with the disturbance

$\delta$  = x-component of the wave vector

$\kappa$  = z-component of the wave vector for the  $n = 0$  harmonic .

$\delta$  is fixed by the incident wave in the half-space problem or the waveguide geometry for the waveguide problem.  $\kappa$  is determined from the dispersion equation.

The dispersion equation is found by replacing, in the wave equation 2B-1,  $E$  by its expression from 2B-2. We have

$$\begin{aligned} \epsilon(z, t) = \epsilon_0 \epsilon_r [1 + \epsilon_1 \cos(Kz - \Omega t)] &= \epsilon_0 \epsilon_r \left[ 1 + \frac{\epsilon_1}{2} e^{i(Kz - \Omega t)} \right. \\ &\left. + \frac{\epsilon_1}{2} e^{-i(Kz - \Omega t)} \right] \end{aligned}$$

so

$$\begin{aligned} \epsilon E &= \epsilon_0 \epsilon_r \sum_n E_n e^{i\delta x + i(\kappa + nK)z - i(\omega + n\Omega)t} \\ &+ \epsilon_0 \epsilon_r \frac{\epsilon_1}{2} \sum_n E_n e^{i\delta x + i(\kappa + nK + K)z - i(\omega + n\Omega + \Omega)t} + \end{aligned}$$

$$\begin{aligned} & \epsilon_o \epsilon_r \frac{\epsilon_1}{2} \sum_n E_n e^{i\delta x + i(\kappa + nK)z - i(\omega + n\Omega - \Omega)t} \\ = & \sum_n \epsilon_o \epsilon_r (E_n + \frac{\epsilon_1}{2} E_{n-1} + \frac{\epsilon_1}{2} E_{n+1}) e^{i\delta x + i(\kappa + nK)z - i(\omega + n\Omega)t} \\ \mu_o \frac{\partial^2 \epsilon E}{\partial t^2} = & - \sum_n \beta_n^2 (E_n + \frac{\epsilon_1}{2} E_{n-1} + \frac{\epsilon_1}{2} E_{n+1}) e^{i\delta x + i(\kappa + nK)z - i(\omega + n\Omega)t} \end{aligned}$$

where  $\beta_n^2 = \mu_o \epsilon_o \epsilon_r (\omega + n\Omega)^2$

and

$$\nabla^2 E = - \sum_n [\delta^2 + (\kappa + nK)^2] E_n e^{i\delta x + i(\kappa + nK)z - i(\omega + n\Omega)t}$$

Putting these expressions into the wave equation, we get

$$\begin{aligned} \sum_n [\beta_n^2 (E_n + \frac{\epsilon_1}{2} E_{n+1} + \frac{\epsilon_1}{2} E_{n-1}) - \delta^2 E_n - (\kappa + nK)^2 E_n] \\ \times e^{i\delta x + i(\kappa + nK)z - i(\omega + n\Omega)t} = 0 \end{aligned}$$

To satisfy this equation for all values of  $x, z$  and  $t$ , the variables  $E_n$  must be the solution of the infinite set of homogeneous equations

$$[\beta_n^2 - \delta^2 - (\kappa + nK)^2] E_n + \frac{\epsilon_1}{2} \beta_n^2 E_{n+1} + \frac{\epsilon_1}{2} \beta_n^2 E_{n-1} = 0 \quad (2B.3)$$

or

$$D_n E_n + E_{n+1} + E_{n-1} = 0 \quad (2B.4)$$

where

$$D_n = \frac{2}{\epsilon_1} \left[ 1 - \frac{\delta^2 + (\kappa + nK)^2}{\beta_n^2} \right]$$

This system of equations will have a nontrivial solution if

its determinant  $\Delta(\kappa, \delta, \omega)$  vanishes, so

$$\Delta(\kappa, \delta, \omega) = 0 \quad (2B.5)$$

and this is the dispersion equation. Solving 2B.5 we can plot the corresponding wave vector diagram.

In order to have an insight on the wave vector diagram without any numerical computation, let us study the limit when  $\epsilon_1 \rightarrow 0$ .

If the modulation (i.e., disturbance) amplitude goes to zero, then from 2B.3 we get

$$\beta_n^2 - \delta^2 - (\kappa + nK)^2 = 0$$

or

$$\delta^2 + (\kappa + nK)^2 = \mu_o \epsilon_o \epsilon_r (\omega + n\Omega)^2$$

which can be written

$$Y^2 + (X + n)^2 = \frac{1}{R^2} \left( \frac{\omega}{\Omega} + n \right)^2$$

where

$$Y = \delta/K$$

$$X = \kappa/K$$

$$\beta_o = \omega \sqrt{\mu_o \epsilon_o \epsilon_r}$$

$$K_o = \Omega \sqrt{\mu_o \epsilon_o \epsilon_r}$$

$$R = K/K_o$$

This is the equation of a family of circles centered at  $X = -n$  with radius  $\frac{1}{R} \left( \frac{\omega}{\Omega} + n \right)$ . For  $\epsilon_1 = 0$  only the  $n = 0$  harmonic has physical meaning.

Figure 2 gives the wave vector diagram for  $\epsilon_1 \rightarrow 0$ ,  $R = 3.5$  and  $\omega/\Omega = 2.5$ . On this diagram we see that there are intersection points between two modes, so when  $\epsilon_1 \neq 0$ , strong interactions will occur around these points.

Solving the dispersion equation and plotting the wave vector diagram for  $\epsilon_1 = 0.25$ ,  $R = 3.5$  and  $\omega/\Omega = 2.5$ , we get stop bands near the intersection points (Fig. 3). In these bands the solution for  $\kappa$  is complex and  $\kappa = \kappa_r + i\kappa_i$ .

A very important result which comes from this diagram is that, for a fixed value of  $\delta$ , there is an infinite number of solutions for  $\kappa$  which satisfy the dispersion equation, so we have  $\kappa = \kappa_q$  where  $q$  represents all integers  $\epsilon ]-\infty, +\infty[$  and the  $\kappa_q$  are real, imaginary or complex. The expression of the field, using the principle of superposition has now to be written

$$E(x, z, t) = \sum_{n=-\infty}^{+\infty} \sum_{q=-\infty}^{+\infty} E_{nq} e^{i\delta x + i(\kappa_q + nK)z - i(\omega + n\Omega)t} \quad (2B.6)$$

where  $E_{nq}$  is the amplitude of the  $n^{\text{th}}$  harmonic of the  $q^{\text{th}}$  mode. The properties of  $\kappa_q$  will be studied later.

To be able to see some of the effects due to the motion of the disturbance, let us compare the wave vector diagram of Fig. 3 to the diagram on Fig. 4 which corresponds to a stationary disturbance (i.e.,  $\Omega = 0$  or  $v_d = 0$ ).

Let  $\Lambda$  = wavelength of the disturbance

$\lambda$  = wavelength of the e.m. wave in the undisturbed medium

$v_o$  = e.m. wave velocity  $1/\sqrt{\mu_o \epsilon_o \epsilon_r}$

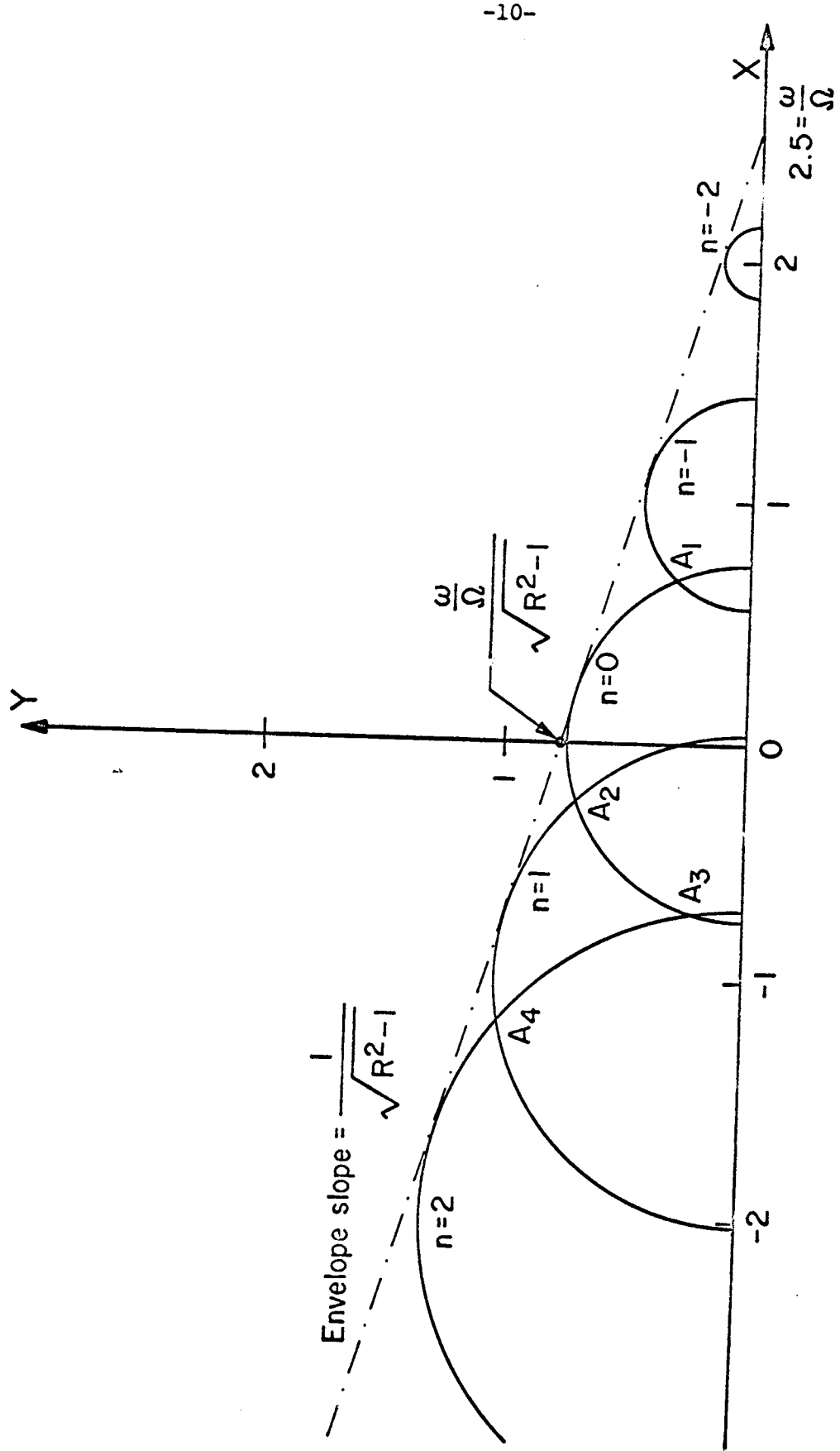

Fig. 2. Wave vector diagram:  $\omega/\Omega = 2.5$ ,  $R = 3.5$ ,  $\epsilon_1 \rightarrow 0$

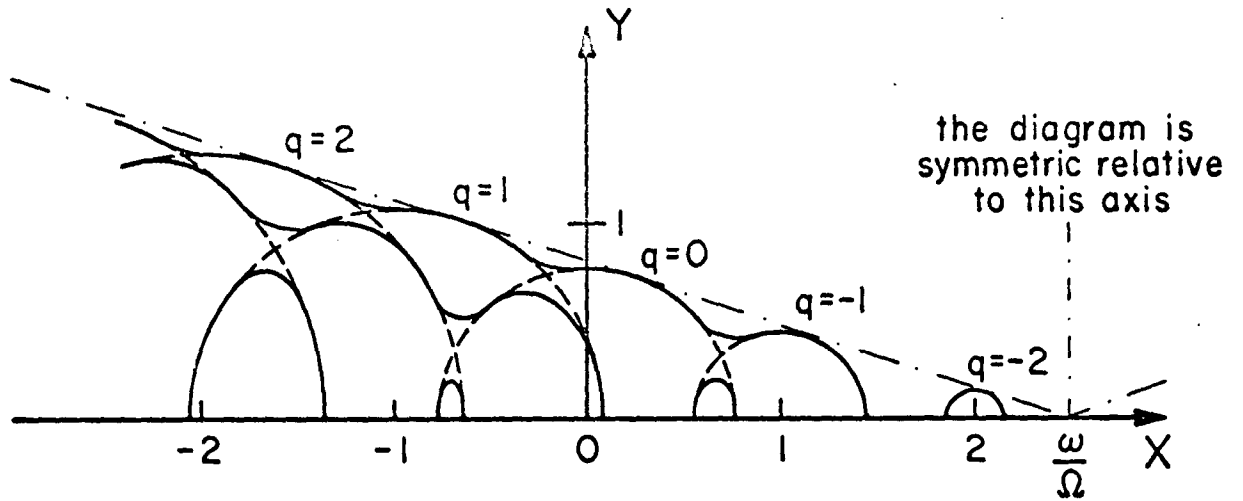

Fig. 3. Dielectric wave vector diagram:  $\epsilon_1 = 0.25$ ,  $R = 3.5$ ,  
 $\omega/\Omega = 2.5$ . Dashed line corresponds to  $\epsilon_1 \rightarrow 0$

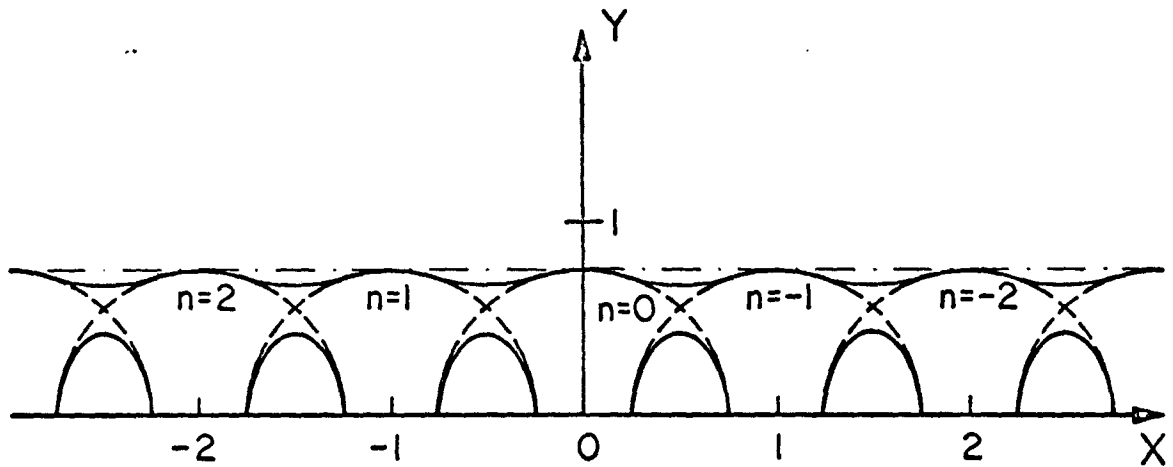

Fig. 4. Dielectric wave vector diagram:  $\epsilon_1 = 0.25$ ,  $v_d = 0$ ,  
 $\lambda/\Lambda = 1.4$ ,  $R = \infty$ . Dashed line corresponds to  $\epsilon_1 \rightarrow 0$ .



$v_d$  = disturbance velocity

$$R = K/K_0 = v_0/v_d$$

$$\frac{R\Omega}{\omega} = \frac{v_0}{v_d} \frac{\Omega}{\omega} = \frac{\lambda}{\Lambda}$$

In both Figs. 3 and 4 we have  $\epsilon_1 = 0.25$  and  $\lambda/\Lambda = 1.4$ . Three interesting effects caused by the motion of the disturbance appear:

- 1) In Fig. 3 the diagram envelope is an oblique straight line with an inclination angle  $\alpha = \sin^{-1}(v_d/v_0)$
- 2) In the stationary disturbance case  $\kappa_q = \pm\kappa_0 + qK$  where  $\kappa_0$  is the value of  $\kappa$  for the fundamental mode, and the field expression is

$$\begin{aligned} E &= \sum_n \sum_q E_{nq} e^{i\delta x + i(\pm\kappa_0 + nK + qK)z - i\omega t} \\ &= \sum_m E_m e^{i\delta x + i(\pm\kappa_0 + mK)z - i\omega t} \end{aligned}$$

$$\text{where } m = n + q \text{ and } E_m = \sum_n E_{n, m-n} .$$

As soon as there is a motion of the disturbance, the relation between the different  $\kappa_q$  is lost, degeneracy and shifting of the stop-bands occur. This implies that for a fixed value of  $\delta$  some modes will propagate, some will be attenuated and some will be cut off. This is a major change relative to the stationary case where all modes behave in the same way, they are all propagating, all attenuated or all cut off, depending on the value of  $\delta$ .

- 3) For the fundamental mode the two solutions for  $\kappa$  are not any more equal in absolute value, as in the stationary case, because of the dissymmetry introduced by the motion of the disturbance in one direction. Also, the two solutions for each of the other modes are not any more symmetric relative to the center of the corresponding circle in the wave vector diagram.

In both moving and stationary cases, for  $\epsilon_1 \neq 0$  there are inflection points in the wave vector diagram. These points will play a major role when we study the dipole radiation.

b. Harmonic amplitudes

The infinite system of linear equations 1B.4 has now to be written

$$D_{nq} E_{nq} + E_{n+1,q} + E_{n-1,q} = 0 \quad (2B.7)$$

where

$$D_{nq} = \frac{2}{\epsilon_1} \left[ 1 - \frac{\delta^2 + (\kappa_q + nK)^2}{\beta_n^2} \right]$$

As we take  $\kappa = \kappa_q$ , this system has a nontrivial solution, but since it is homogeneous we only can determine the values of  $C_{nq} = E_{nq}/E_{oq}$ .

It is straightforward to find that (see Appendix B)

$$\frac{E_{nq}}{E_{n-1,q}} = - \frac{1}{D_{nq} - \frac{1}{D_{n+1,q} - \frac{1}{\ddots}}} \quad \text{for } n \geq 0$$

$$\frac{E_{nq}}{E_{n+1,q}} = - \frac{1}{D_{nq} - \frac{1}{D_{n-1,q} - \frac{1}{\dots}}} \quad \text{for } n < 0$$

Then we have

$$C_{nq} = \frac{E_{n,q}}{E_{o,q}} = \frac{E_{n,q}}{E_{n-1,q}} \times \frac{E_{n-1,q}}{E_{n-2,q}} \dots \frac{E_{1,q}}{E_{o,q}} \quad \text{for } n > 0$$

$$C_{nq} = \frac{E_{n,q}}{E_{o,q}} = \frac{E_{nq}}{E_{n+1,q}} \times \frac{E_{n+1,q}}{E_{n+2,q}} \dots \frac{E_{-1,q}}{E_{o,q}} \quad \text{for } n < 0 \quad (2B.8)$$

and the values of  $E_{oq}$  will be determined by:

- the boundary conditions for the half-space;
- the source condition for the dipole.

c. Convergence

A last factor to complete the solution is to study the convergence of the system 2B.7.

The convergence condition for a system of difference equations

$$D_n V_n + V_{n+1} + V_{n-1} = 0$$

is given by

$$\left| \lim_{n \rightarrow \infty} D_n \right| > 2 \quad (\text{Poincare theorem [16,21]})$$

This gives

$$\frac{2}{\epsilon_1} |1 - R^2| > 2$$

or  $R > \sqrt{1 + \epsilon_1}$  for  $R > 1$

$$R < \sqrt{1 - \epsilon_1} \quad \text{for } R < 1$$

So the solution will converge for all values of  $R$  or  $v_d$  outside of the region

$$\sqrt{1 - \epsilon_1} \leq R \leq \sqrt{1 + \epsilon_1}$$

or

$$\frac{v_0}{\sqrt{1 + \epsilon_1}} \leq v_d \leq \frac{v_0}{\sqrt{1 - \epsilon_1}}$$

This divergence region is called the sonic region, in which there is a blow up of all the harmonics. This condition of convergence excludes from our study the case of a disturbance created by an e.m. wave in the dielectric. (This last remark is valid only for an isotropic dielectric; for plasma and anisotropic media, see the corresponding chapters).

## 2. Transverse magnetic field

### a. Dispersion equation

$$\text{We have } \underline{E} = E_x \underline{e}_x + E_z \underline{e}_z$$

$$\underline{H} = H \underline{e}_y$$

The field can be found from the electric Hertz vector wave equation 2A.11, or directly from Maxwell's equations. Here, the second method is used.

The field equations are:

$$\nabla \times \underline{E} = -\mu_0 \frac{\partial H}{\partial t} \implies \frac{\partial E_x}{\partial z} - \frac{\partial E_z}{\partial x} = -\mu_0 \frac{\partial H}{\partial t} \quad (2B.9)$$

$$\nabla \times \underline{H} = \frac{\partial}{\partial t} (\epsilon \underline{E}) \Rightarrow -\frac{\partial H}{\partial z} = \frac{\partial}{\partial t} (\epsilon E_x) \quad (2B.10)$$

$$\frac{\partial H}{\partial x} = \frac{\partial}{\partial t} (\epsilon E_z) \quad (2B.11)$$

$$\nabla \cdot \underline{H} = 0 \Rightarrow \frac{\partial H}{\partial y} = 0 \quad (2B.12)$$

$$\nabla \cdot (\epsilon \underline{E}) = 0 \Rightarrow \epsilon \frac{\partial E_x}{\partial x} + \frac{\partial}{\partial z} (\epsilon E_z) = 0 \quad (2B.13)$$

Using Floquet's theorem and the superposition principle, as we did in the T.E. case, the field expressions can be written:

$$H = \sum_n H_n e^{i\delta x + i(\kappa + nK)z - i(\omega + n\Omega)t}$$

$$\underline{E} = \sum_n \underline{E}_n e^{i\delta x + i(\kappa + nK)z - i(\omega + n\Omega)t}$$

$$= \sum_n (E_{nx} \underline{e}_x + E_{nz} \underline{e}_z) e^{i\delta x + i(\kappa + nK)z - i(\omega + n\Omega)t}$$

Putting these expressions in 2B.9, 2B.10 and 2B.11, and following the same procedure as in the T.E. case (i.e., equating the elements corresponding to the same harmonic), we get

$$(\kappa + nK)E_{nx} - \delta E_{nz} = \mu_o (\omega + n\Omega) H_n$$

$$-(\kappa + nK)H_n = -\epsilon_o \epsilon_r (\omega + n\Omega) (E_{nx} + \frac{\epsilon_1}{2} E_{n+1,x} + \frac{\epsilon_1}{2} E_{n-1,x})$$

$$\delta H_n = -\epsilon_o \epsilon_r (\omega + n\Omega) (E_{nz} + \frac{\epsilon_1}{2} E_{n+1,z} + \frac{\epsilon_1}{2} E_{n-1,z})$$

Eliminating  $H_n$  the above system reduces to

$$D_n E_{nx} + E_{n+1,x} + E_{n-1,x} + G_n E_{nz} = 0 \quad (2B.14)$$

$$D'_n E_{nz} + E_{n+1,z} + E_{n-1,z} + G_n E_{nx} = 0 \quad (2B.15)$$

where

$$D_n = \frac{2}{\epsilon_1} \left[ 1 - \left( \frac{\kappa + nK}{\beta_n} \right)^2 \right]$$

$$D'_n = \frac{2}{\epsilon_1} \left[ 1 - \left( \frac{\delta}{\beta_n} \right)^2 \right]$$

$$G_n = \frac{2}{\epsilon_1} \frac{\delta(\kappa + nK)}{\beta_n^2}$$

From 2B.15 we have

$$E_{nx} = -\frac{D'_n}{G_n} E_{n,z} - \frac{1}{G_n} E_{n+1,z} - \frac{1}{G_n} E_{n-1,z}$$

$$E_{n+1,x} = -\frac{D'_{n+1}}{G_{n+1}} E_{n+1,z} - \frac{1}{G_{n+1}} E_{n+2,z} - \frac{1}{G_{n+1}} E_{n,z}$$

$$E_{n-1,x} = -\frac{D'_{n-1}}{G_{n-1}} E_{n-1,z} - \frac{1}{G_{n-1}} E_{n,z} - \frac{1}{G_{n-1}} E_{n-2,z}$$

Putting these expressions in 2B.14 gives

$$\begin{aligned} & \left[ \frac{D_n D'_n - G_n^2}{G_n} + \frac{1}{G_{n+1}} + \frac{1}{G_{n-1}} \right] E_{nz} + \left[ \frac{D_n}{G_n} + \frac{D'_{n+1}}{G_{n+1}} \right] E_{n+1,z} \\ & + \left[ \frac{D_n}{G_n} + \frac{D'_{n-1}}{G_{n-1}} \right] E_{n-1,z} + \frac{1}{G_{n+1}} E_{n+2,z} + \frac{1}{G_{n-1}} E_{n-2,z} = 0 \end{aligned} \quad (2B.16)$$

or in a matrix form

$$||M|| \cdot |E_z| = 0 \quad (2B.17)$$

where

$|E_z|$  is a column vector with elements  $E_{nz}$

$||M||$  is a matrix with elements:

$$M_{n,n} = \frac{D_n D'_n - G_n^2}{G_n} + \frac{1}{G_{n+1}} + \frac{1}{G_{n-1}}$$

$$M_{n,n+1} = \frac{D_n}{G_n} + \frac{D'_{n+1}}{G_{n+1}}$$

$$M_{n,n-1} = \frac{D_n}{G_n} + \frac{D'_{n-1}}{G_{n-1}}$$

$$M_{n,n+2} = \frac{1}{G_{n+1}}$$

$$M_{n,n-2} = \frac{1}{G_{n-2}}$$

and all the other elements are equal to zero.

To get a nontrivial solution for  $|E_z|$  the determinant of  $||M||$  must vanish

$$\Delta'(\delta, \kappa, \omega) = \text{Det } ||M|| = 0 \quad (2B.18)$$

This equation is the dispersion relation and it gives the wave vector diagram for the T.M. case.

In the limit  $\epsilon_1 \rightarrow 0$ , taking the highest order of  $1/\epsilon_1$ , equation 2B.16 reduces to

$$\left( \frac{D_n D'_n - G_n^2}{G_n} \right) E_{nz} = 0$$

and the corresponding dispersion equation becomes  $D_n D'_n = G_n^2$ , and for

$\beta_n \neq 0$

$$(\kappa + nK)^2 + \delta^2 = \beta_n^2$$

which is the same as in the T.E. case. This is to be expected because the dispersion equation for T.E. and T.M. waves in homogeneous isotropic media (i.e., when  $\epsilon_1 = 0$ ) is unique.

The wave vector diagram in Fig. 2 applies for the T.M. wave when  $\epsilon_1 \rightarrow 0$ . For  $\epsilon_1 \neq 0$  the T.M. wave vector diagram is similar to the T.E. diagram in Fig. 3 (but not exactly the same), and  $\kappa$  is multivalued. Then the field expression is

$$H = \sum_n \sum_q H_{nq} e^{i\delta x + i(\kappa_q + nK)z - i(\omega + n\Omega)t}$$

$$\underline{E} = \sum_n \sum_q (E_{nqx} \underline{e}_x + E_{nqz} \underline{e}_z) e^{i\delta x + i(\kappa_q + nK)z - i(\omega + n\Omega)t}$$

The values of  $\kappa_q$  are determined from the dispersion equation or the corresponding wave vector diagram.

The same remarks made about the effects of the disturbance or its motion on the T.E. field apply to the T.M. field too.

b. Harmonic amplitudes

Equation 2B.17 gives the ratios  $C'_{nq} = \frac{E_{nqz}}{E_{oqz}}$ ; then using 2B.9 and 2B.15 we get

$$B'_{nq} = \frac{E_{nqx}}{E_{oqz}} = - \left[ \frac{D'_{nq}}{G_{nq}} C'_{nq} + \frac{1}{G_{nq}} C'_{n+1,q} + \frac{1}{G_{nq}} C'_{n-1,q} \right]$$

$$A'_{nq} = \frac{H_{nq}}{E_{oqz}} = - \frac{\epsilon_0 \omega_n}{\delta} \left[ C'_{nq} + \frac{\epsilon_1}{2} C'_{n+1,q} + \frac{\epsilon_1}{2} C'_{n-1,q} \right]$$
(2B.19)

where  $\omega_n = \omega + n\Omega$  and the set  $E_{oqz}$  is determined by the



boundary conditions or the source conditions.

For  $\delta = 0$  (i.e., normal incidence), equations 2B.19 are not valid and we must use 2B.14 and 2B.15.

c. Convergence

When  $n \rightarrow \infty$  equation 2B.16 becomes

$$AE_{nz} + BE_{n+1,z} + BE_{n-1,z} + E_{n+2,z} + E_{n-2,z} = 0$$

where

$$A = 2 + \frac{4}{\epsilon_1} (1 - R^2)$$

$$B = \frac{2}{\epsilon_1} (2 - R^2)$$

This is a fourth-order difference equation, and from Poincare theorem [18,21] the divergence or sonic region is given by

$$-2(B + 1) \leq A \leq 2(B - 1) \quad \text{for } B > 4$$

and

$$-2(B + 1) \leq A \leq B^2/4 + 2 \quad \text{for } B < 4$$

or replacing A and B by their expressions in terms of R :

$$1 - \epsilon_1 \leq R^2 \leq 1 + \epsilon_1 \quad \text{for } R^2 < 2(1 - \epsilon_1)$$

$$0 \leq R^2 \leq 1 + \epsilon_1 \quad \text{for } R^2 > 2(1 - \epsilon_1)$$

These inequalities can be written in one relation as

$$1 - \epsilon_1 \leq R^2 \leq 1 + \epsilon_1 \quad \text{for all } R$$

So the sonic region for the T.E. and T.M. fields is the same.

C. Reflection and Transmission: Half-Space

We assume a wave is incident upon a semi-infinite medium where

$$\epsilon(z,t) = \epsilon_0 \epsilon_r [1 + \epsilon_1 \cos(Kz - \Omega t)]$$

with an incidence angle  $\theta_i$ . The reflected and transmitted waves will contain harmonics with frequencies  $\omega_n = \omega + n\Omega$ , because of the interaction with the disturbance in the dielectric (see Fig. 5).

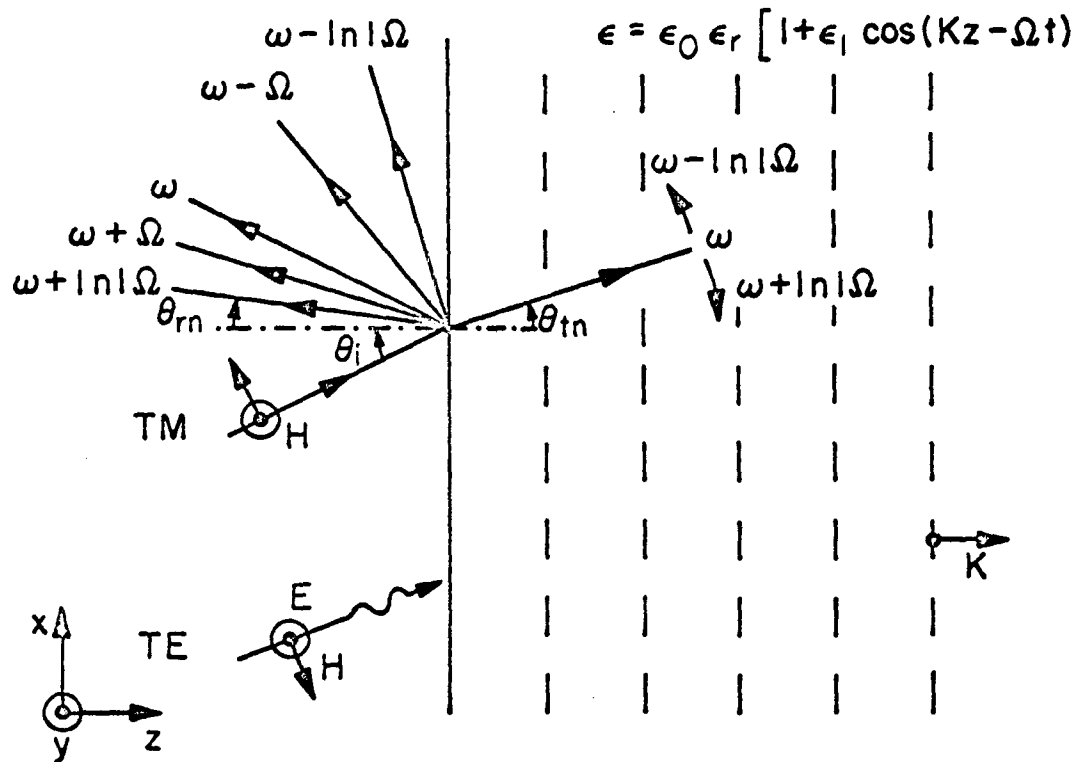

Fig. 5. Half space case

1. T.E. incident wave (Fig. 5):

The normalized incident wave is

$$\begin{aligned} \underline{E}_i &= \underline{e}_y e^{i(\beta_i \sin \theta_i x + \beta_i \cos \theta_i z - \omega t)} \\ H_{ix} &= -\cos \theta_i \sqrt{\epsilon_o/\mu_o} e^{i(\beta_i \sin \theta_i x + \beta_i \cos \theta_i z - \omega t)} \end{aligned} \quad (2C.1)$$

$$H_{iz} = \sin \theta_i \sqrt{\epsilon_o/\mu_o} e^{i(\beta_i \sin \theta_i x + \beta_i \cos \theta_i z - \omega t)}$$

where  $\beta_i^2 = \mu_o \epsilon_o \omega^2$

The x component of the wave vector is the same for the incident wave and all the components of the transmitted and reflected waves.

The reflected wave can be written:

$$\underline{E}_r = \underline{e}_y \sum_n R_n e^{i(\beta_i \sin \theta_i x - \beta_{in} \cos \theta_{rn} z - \omega_n t)} \quad (2C.2)$$

$$H_{rx} = \sqrt{\epsilon_o/\mu_o} \sum_n R_n \cos \theta_{rn} e^{i(\beta_i \sin \theta_i x - \beta_{in} \cos \theta_{rn} z - \omega_n t)}$$

where

$$\beta_{in}^2 = \mu_o \epsilon_o \omega_n^2$$

We must have  $(\beta_i \sin \theta_i)^2 + (\beta_{in} \cos \theta_{rn})^2 = \beta_{in}^2$ , therefore

$$\cos^2 \theta_{rn} + \left(\frac{\omega}{\omega_n}\right)^2 \sin^2 \theta_i = 1$$

or

$$\sin \theta_{rn} = \frac{\sin \theta_i}{1 + n \frac{\omega}{\omega_n}} \quad (2C.3)$$

The transmitted wave is

$$\frac{E}{t} = \frac{e}{y} \sum_n \sum_q t_q E_{nq} e^{i(\kappa_q + nK)z + i\beta_i \sin \theta_i x - \omega_n t} \quad (2C.4)$$

$$H_{tx} = \sum_n \sum_q -\frac{\kappa_q + nK}{\mu_o \omega_n} t_q E_{nq} e^{i(\kappa_q + nK)z + i\beta_i \sin \theta_i x - \omega_n t}$$

The values of  $\kappa_q$  are determined from the wave vector diagram with

$$\delta = \beta_i \sin \theta_i .$$

At the boundary ( $z = 0$ ) the continuity of  $E$  and  $H_x$  gives

$$e^{-i\omega t} + \sum_n R_n e^{-i\omega_n t} = \sum_n \sum_q t_q E_{nq} e^{-i\omega_n t}$$

and

$$\sqrt{\frac{\epsilon_o}{\mu_o}} e^{-i\omega t} \cos \theta_i - \sqrt{\frac{\epsilon_o}{\mu_o}} \sum_n R_n \cos \theta_{rn} e^{-i\omega_n t} = \sum_n \sum_q \frac{\kappa_q + nK}{\mu_o \omega_n} t_q E_{nq} e^{-i\omega_n t}$$

These equations must be satisfied for all values of  $t$ , therefore the terms with the same frequency must be equal. This gives the set of equations:

$$\delta(n,0) + R_n = \sum_q t_q E_{nq} \quad (2C.5)$$

$$\delta(n,0) \cos \theta_i - R_n \cos \theta_{rn} = \sum_q \frac{\kappa_q + nK}{\beta_{in}} t_q E_{nq} \quad (2C.6)$$

where  $\delta(i,j)$  is the Kroenicker delta

$$\begin{cases} \delta(i,i) = 1 \\ \delta(i,j) = 0 \quad \text{for } i \neq j \end{cases}$$

Eliminating  $R_n$  we get

$$\delta(n,0)[\cos \theta_i + \cos \theta_{rn}] - \cos \theta_{rn} \sum_q t_q E_{nq} = \sum_q \frac{\kappa_q + nK}{\beta_{in}} t_q E_{nq}$$

but

$$\delta(n,0) \cos \theta_{rn} = \delta(n,0) \cos \theta_{ro} = \delta(n,0) \cos \theta_i$$

so

$$2\delta(n,0) \cos \theta_i = \sum_q \left( \cos \theta_{rn} + \frac{\kappa_q + nK}{\beta_{in}} \right) t_q E_{nq}$$

This equation can be written

$$\sum_q B_{nq} T_q = 2\delta(n,0) \cos \theta_i$$

where

$$B_{nq} = \left( \cos \theta_{rn} + \frac{\kappa_q + nK}{\beta_{in}} \right) C_{nq} = \left( \sqrt{1 - \frac{\sin^2 \theta_i}{(1+n\frac{\Omega}{\omega})^2}} + \frac{\kappa_q + nK}{\beta_{in}} \right) C_{nq}$$

$$C_{nq} = \frac{E_{nq}}{E_{oq}}$$

$$T_q = t_q E_{oq}$$

or in a matrix form

$$||B|| \cdot |T| = |V| \quad (2C.7)$$

where

$$||B|| = \text{matrix with elements } B_{nq}$$

$$|T| = \text{column vector with elements } T_q$$

$$|V| = \text{column vector with elements } \begin{cases} V_n = 2 \cos \theta_i & \text{for } n = 0 \\ V_n = 0 & \text{for } n \neq 0 \end{cases}$$

Equation 2C-7 gives

$$|T| = ||B||^{-1} |V|$$

and the transmitted field is completely determined by

$$E_t = \sum_q \sum_n C_{nq} T_q e^{i(\kappa_q + nK)z + i\beta_1 \sin \theta_1 x - i\omega_n t}$$

Writing 2C.5 in a matrix form, we have

$$|V'| + |R| = ||C|| \cdot |T|$$

then

$$|R| = -|V'| + ||C|| \cdot ||B||^{-1} \cdot |V| \quad (2C.8)$$

where

$$\begin{aligned} ||C|| &= \text{matrix with elements } C_{nq} \\ |V'| &= \text{column vector with elements } \begin{cases} V_n = 1 & \text{for } n = 0 \\ V_n = 0 & \text{for } n \neq 0 \end{cases} \\ |R| &= \text{column vector with elements } R_n \end{aligned}$$

This equation gives all the reflection coefficients.

a. Reflection angle

The reflection angles are given by 2C.3

$$\sin \theta_{rn} = \frac{\sin \theta_1}{1 + n \frac{\Omega}{\omega}}$$

The high frequency harmonics ( $n > 0$ ) will be reflected near the normal, the low frequency harmonics ( $n < 0$ ) will be reflected near the boundary, and the harmonics with  $n < \frac{\omega}{\Omega}(-1 + \sin \theta_1)$  will not be reflected at all. So in reality, the reflected field will contain only

the harmonics with frequencies

$$\omega > \omega_{co} = \omega \sin \theta_i$$

(see Fig. 5).

b. Transmission angle

The transmitted wave is

$$\underline{E}_t = \underline{e}_y \sum_n \sum_q C_{nq} T_q e^{i(\kappa_q + nK)z + i\beta_i \sin \theta_i x - i\omega_n t}$$

and the wave vector components are

$$k_x = \delta = \beta_i \sin \theta_i = \sqrt{\mu_o \epsilon_o} \omega \sin \theta_i$$

$$k_z = \kappa_q(\delta) + nK = \kappa_q(\omega) + nK$$

The group angle  $\psi$  (i.e., angle between the group velocity vector  $\underline{v}_g$  and the vector  $\underline{e}_z$ ) is different from the phase angle  $\theta_t$  (i.e., angle between the wave vector  $\underline{k}$  and  $\underline{e}_z$ ). These two angles are given by:

$$\text{tg } \theta_{tnq} = \frac{k_x}{k_z} = \frac{\sqrt{\mu_o \epsilon_o} \omega \sin \theta}{\kappa_q(\omega) + nK}$$

$$\text{tg } \psi_{nq} = \frac{v_{gx}}{v_{gz}} = \frac{\partial \kappa_q}{\partial \delta}$$

For a certain mode  $q$  all the harmonics  $n$  will have the same group angle, which can be found from the slope at the corresponding point on the wave vector diagram.

c. Transmitted wave vector

The incident wave fixes the value of  $\delta$

$$\delta = \beta_i \sin \theta_i$$

or

$$Y_i = \frac{\delta}{K} = \frac{\beta_i}{K} \sin \theta_i = \sqrt{\epsilon_r} \frac{\Lambda}{\lambda} \sin \theta_i$$

where

$$\Lambda = \text{disturbance wavelength}$$

$$\lambda = \text{e.m. wavelength} = 2\pi / \omega \sqrt{\mu_o \epsilon_o \epsilon_r}$$

In Fig. 6 the mode  $q = 0$  is represented by the curve ABCDEFGH, and the dotted line corresponds to a complex  $\kappa$ .

Let us examine the characteristics of the transmitted wave for different values of the incident angle (see Fig. 6):

$-Y_i = Y_1$  : This corresponds to  $\sqrt{\epsilon_r} \sin \theta_i > 1$ . The modes  $q = 0, -1, -2$  are cut off and the major contribution comes from the mode  $q = 1$ .

$-Y_i = Y_2$  : The mode  $q = 0$  gives a backward propagating wave (negative slope on the diagram) and an exponentially attenuated forward wave (intersection with the dotted line in the stop band). This possibility of having only a propagating backward wave for a certain mode is due to the motion of the disturbance. The modes  $q = -1, -2$  are still cut off.

$-Y_i = Y_3$  : The mode  $q = 0$  gives a propagating forward wave but an exponentially attenuated backward wave.



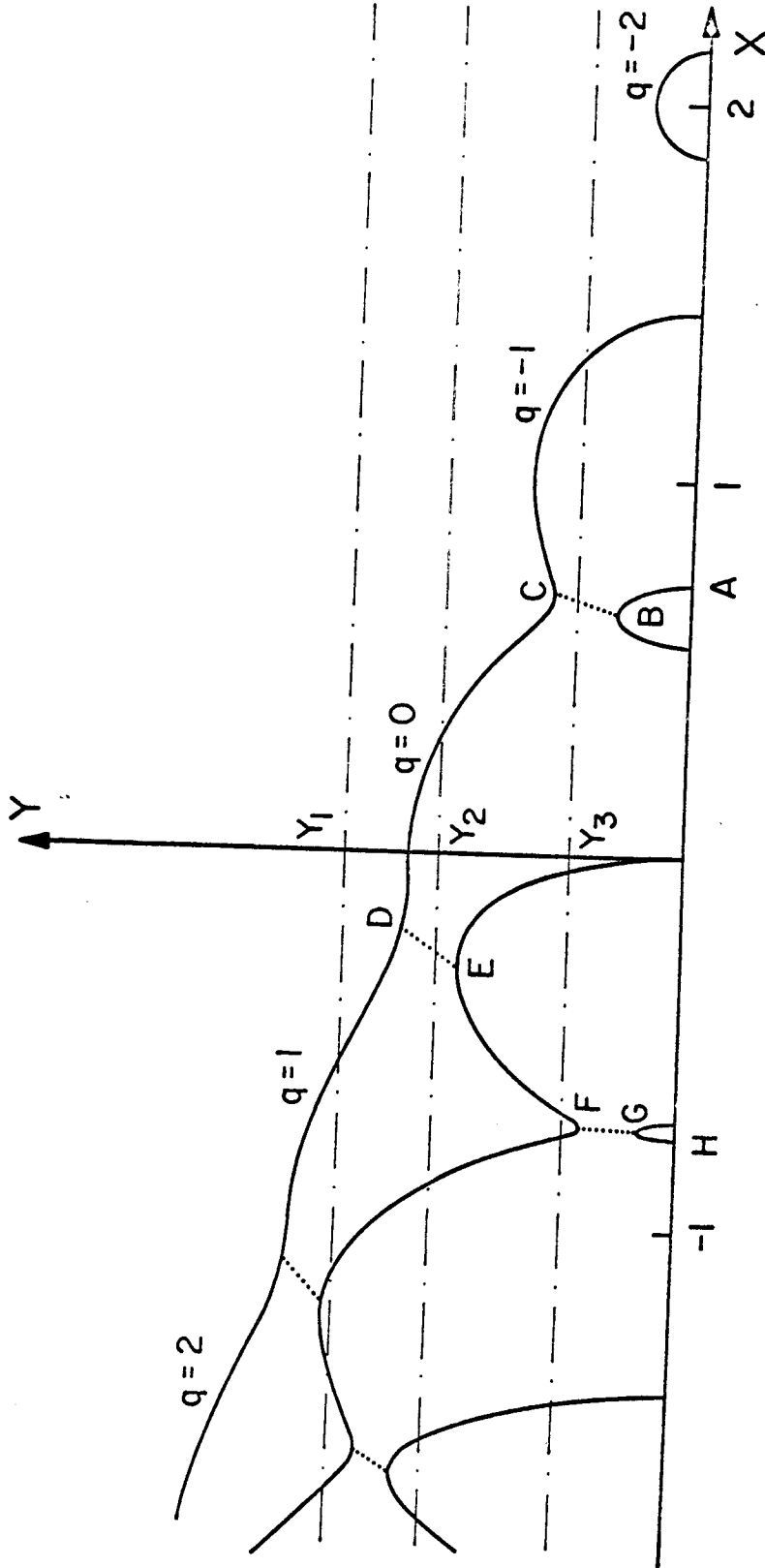

Fig. 6. Wave vector diagram. The dotted parts correspond to stop bands where the wave vector is complex.

2. T.M. incident wave (Fig. 5)

The normalized incident wave is

$$\underline{E} = (\cos \theta_i \underline{e}_x - \sin \theta_i \underline{e}_z) e^{i(\beta_i \sin \theta_i x + \beta_i \cos \theta_i z) - i\omega t}$$

$$\underline{H} = \sqrt{\epsilon_o/\mu_o} \underline{e}_y e^{i(\beta_i \sin \theta_i x + \beta_i \cos \theta_i z) - i\omega t}$$

the reflected wave is

$$\underline{E}_r = \sum_n (R_n \cos \theta_{rn} \underline{e}_x + R_n \sin \theta_{rn} \underline{e}_z) e^{i(\beta_i \sin \theta_i x + \beta_{in} \cos \theta_{rn} z - \omega_n t)}$$

$$\underline{H}_r = -\underline{e}_y \sum_n \sqrt{\frac{\epsilon_o}{\mu_o}} R_n e^{i(\beta_i \sin \theta_i x + \beta_{in} \cos \theta_{rn} z - \omega_n t)}$$

where

$$\sin \theta_{rn} = \frac{\sin \theta_i}{1 + n \frac{\Omega}{\omega}} = \frac{\omega}{\omega_n} \sin \theta_i$$

and the transmitted wave is

$$\underline{E}_t = \sum_n \sum_q (E_{nqx} \underline{e}_x + E_{nqz} \underline{e}_z) e^{i\beta_i \sin \theta_i x + i(\kappa_q + nK)z - i\omega_n t}$$

$$\underline{H}_t = \underline{e}_y \sum_n \sum_q H_{nq} e^{i\beta_i \sin \theta_i x + i(\kappa_q + nK)z - i\omega_n t}$$

(a slightly different notation than in the T.E. case is used.)

At  $z = 0$  the boundary conditions give, after equating the terms with the same frequency,

$$\delta(o,n) - R_n = \sqrt{\frac{\mu_o}{\epsilon_o}} \sum_q H_{nq} \quad (2C.9)$$

$$\delta(o,n) \cos \theta_i + R_n \cos \theta_{rn} = \sum_q E_{nqx} \quad (2C.10)$$

Eliminating  $R_n$ , we get

$$2\delta(o,n)\cos\theta_i = \sum_q N_{nq} T_q$$

where

$$T_q = E_{oqz}$$

$$N_{nq} = B'_{nq} - A'_{nq} \cos\theta_{rn} = B'_{nq} - A'_{nq} \sqrt{1 - \left(\frac{\omega}{\omega_n} \sin\theta_i\right)^2}$$

$$B'_{nq} = \frac{E_{nqx}}{E_{oqz}} \quad (\text{see 2B.19})$$

$$A'_{nq} = \frac{H_{nq}}{E_{oqz}} \quad (\text{see 2B.19})$$

$\delta(o,n)$  = Kroenecker delta

Using a matrix form, we can write

$$||N|| \cdot |T| = |V|$$

and

$$|T| = ||N||^{-1} \cdot |V| \quad (2C.12)$$

where

$$||N|| = \text{matrix with elements } N_{nq}$$

$$|T| = \text{column vector with elements } T_q$$

$$|V| = \text{column vector with elements } \begin{cases} V_n = 2 \cos\theta_i & \text{for } n=0 \\ V_n = 0 & \text{for } n \neq 0 \end{cases}$$

The reflection column vector  $|R|$ , which has the different reflection coefficients  $R_n$  as elements, is given by

$$|R| = -\sqrt{\epsilon_o/\mu_o} ||A'|| \cdot ||N||^{-1} \cdot |V| - |V'| \quad (2C.13)$$

and the transmitted field is completely determined by

$$\underline{E}_t = \sum_n \sum_q (B'_{nq} e^{-x} + C'_{nq} e^{-z}) T_q e^{i(\beta_i \sin \theta_i)x + i(\kappa_q + nK)z - i\omega_n t}$$

$$\underline{H}_t = \frac{e}{y} \sum_n \sum_q A'_{nq} T_q e^{i\beta_i \sin \theta_i x + i(\kappa_q + nK)z - i\omega_n t}$$

#### D. Guided Waves

Let us consider a cylindrical waveguide with axis parallel to the z-direction, filled with a dielectric which is submitted to a traveling disturbance such that

$$\epsilon = \epsilon(z, t) = \epsilon_o \epsilon_r [1 + \epsilon_1 \cos(Kz - \Omega t)]$$

The value of  $\delta$  is fixed by the geometrical characteristics of the waveguide.

For a rectangular waveguide of dimensions  $L$  and  $\ell$ ,

$$\delta_{mp} = \sqrt{\left(\frac{m\pi}{L}\right)^2 + \left(p \frac{\pi}{\ell}\right)^2}$$

where  $m$  and  $p$  are integers representing the mode excited in the waveguide by the source, not the modes caused by the disturbance.

For a circular waveguide of radius  $R$ , we have

$$J_m(\delta_{mp} R) = 0 \quad \text{or} \quad J'_m(\delta_{mp} R) = 0$$

depending on the excited mode.

Having the values of  $\delta$ , we follow the same methods used in the half space problem to determine the values of  $\kappa_q$ , the cut-off

frequencies, the behavior of the forward and backward waves, and the amplitudes of different harmonics.

E. Transmission and Reflection:

Slab ( $\epsilon_1 \ll 1$ )

In this section we take  $\epsilon_1 \ll 1$  (see Fig. 7). As  $\epsilon_1 \ll 1$ , the electric field expression is

$$\underline{E} = (\underline{E}_0 + \underline{E}_1 e^{i(Kz - \Omega t)} + \underline{E}_{-1} e^{-i(Kz - \Omega t)}) e^{i(\kappa z - \omega t) + i\delta x} \quad (2E.1)$$

where we neglect all the other harmonics.

Let us consider the T.E. case where  $\underline{E} = E \underline{e}_y$ . The system of equations 2B.4 becomes

$$d_0 E_0 + \frac{\epsilon_1}{2} E_1 + \frac{\epsilon_1}{2} E_{-1} = 0 \quad (2E.2)$$

$$d_1 E_1 + \frac{\epsilon_1}{2} E_0 = 0 \quad (2E.3)$$

$$d_{-1} E_{-1} + \frac{\epsilon_1}{2} E_0 = 0 \quad (2E.4)$$

where

$$d_n = \frac{\epsilon_1}{2} D_n = 1 - \frac{\delta^2 + (\kappa + nK)^2}{\beta_n^2}$$

From 2E.3 and 2E.4 we see that usually  $E_1$  and  $E_{-1} \ll E_0$  and to satisfy 2E.2 we must have

$$d_0 \approx 0$$

which gives the dispersion equation in the homogeneous medium

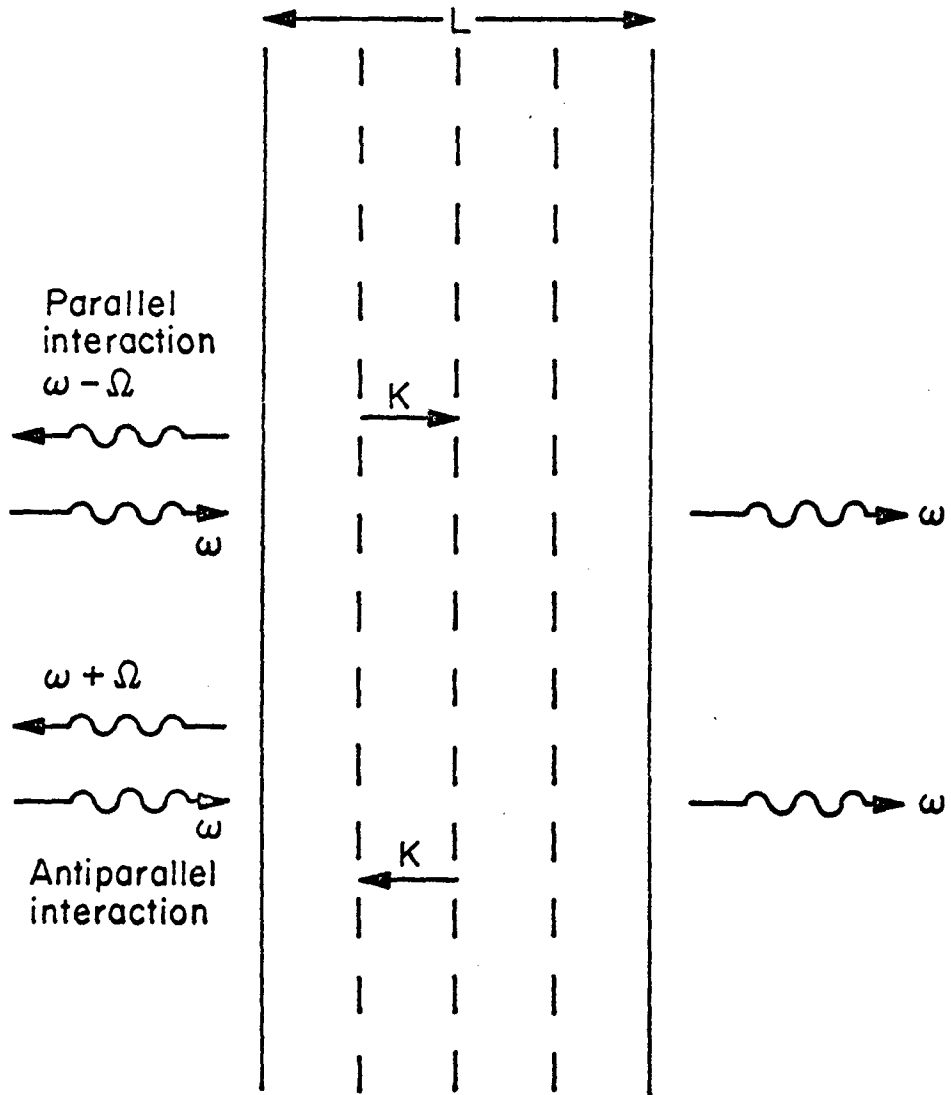

Fig. 7. Transmission and reflection from a slab

$$\delta^2 + \kappa^2 = \beta_0^2$$

But if  $d_0 \approx 0$ , and at the same time  $d_1$  or  $d_{-1} \approx 0$ , then there is energy conversion.

### 1. Up-conversion

Let us suppose the parameters in the problem are such that

$$d_0 \approx 0 \quad \Rightarrow \quad \delta^2 + \kappa^2 = \beta_0^2$$

and

$$d_1 \approx 0 \quad \Rightarrow \quad \delta^2 + (\kappa + K)^2 = \beta_0^2 \left(1 + \frac{\Omega}{\omega}\right)^2$$

This occurs if

$$K^2 + 2K\sqrt{\beta_0^2 - \delta^2} = K_0^2 + 2K_0\beta_0 \quad (2E.5)$$

where

$$K_0 = \sqrt{\mu_0 \epsilon_0 \epsilon_r} \Omega$$

In this case we still have  $E_{-1} \ll E_0$ , but we cannot say any more that  $E_1 \ll E_0$ , and the system of equations becomes

$$d_0 E_0 + \frac{\epsilon_1}{2} E_1 = 0$$

$$d_1 E_1 + \frac{\epsilon_1}{2} E_0 = 0$$

This system solution is not trivial if

$$d_0 d_1 = \frac{\epsilon_1^2}{4} \quad (2E.6)$$

Solving equation 2E.6, we get

$$\kappa = k_{z0} \pm \epsilon_1 \frac{\beta_1 \beta_0}{4k_{z0}} \sqrt{\frac{k_{z0}}{k_{z0} + K}} \quad (2E.7)$$

where

$$k_{z0} = \sqrt{\beta_0^2 - \delta^2}$$

and this gives

$$\frac{E_1}{E_0} = \frac{\omega + \Omega}{\omega} \sqrt{\frac{k_{z0}}{k_{z0} + K}}$$

$$\frac{P_1}{P_0} = \left| \frac{E_1}{E_0} \right|^2 = \left( \frac{\omega + \Omega}{\omega} \right)^2 \left| \frac{k_{z0}}{k_{z0} + K} \right| \quad (2E.8)$$

We see that  $E_1$  is of the order of  $E_0$  and this up-conversion effect occurs only when 2E.5 is satisfied.

For normal incidence ( $\delta = 0$ ), the up-conversion condition becomes

$$\beta_0 = -\frac{K + K_0}{2}$$

but as  $\beta_0$  is positive, then  $K$  must be negative (i.e., the disturbance must propagate opposite to the e.m. wave) and it must be such that  $|K| > K_0$ , then

$$\beta_0 = \frac{|K| - K_0}{2}$$

Three interesting remarks must be mentioned:

1) The condition of up-conversion, 2E.5, is exactly the first-order Bragg condition with moving disturbance. This can be shown from Fig. 8.



2) For oblique incidence, up-conversion can occur for all angles of incidence  $\theta_i$  ( $\theta_i$  = angle between the e.m. wave vector and the disturbance wave vector) such that

$$\phi < \theta_i \leq \pi$$

where

$$\cos \phi = K_o/K = v_d/v_o$$

3) The power conversion ratio is

$$\frac{P_1}{P_o} = \left(\frac{\omega + \Omega}{\omega}\right)^2 \left| \frac{k_{zo}}{k_{zo} + K} \right|$$

$P_o$  and  $P_1$  are power densities. To get the total power we must multiply by the cross sections of the incident and reflected waves.

From Fig. 9 we have

$$\frac{S_r}{S_i} = \frac{L_r}{L_i} = \frac{\cos \theta_r}{\cos \theta_i}$$

but

$$\cos \theta_r = \frac{|k_{zo} + K|}{\beta_1}$$

$$\cos \theta_i = \frac{k_{zo}}{\beta_o}$$

So

$$\frac{P_1 S_r}{P_o S_i} = \left(\frac{\omega + \Omega}{\omega}\right)^2 \left| \frac{k_{zo}}{k_{zo} + K} \right| \left(\frac{\beta_o}{\beta_1}\right) \left| \frac{k_{zo} + K}{k_{zo}} \right| = \frac{\omega + \Omega}{\omega}$$

and this is the Manley-Rowe relation.

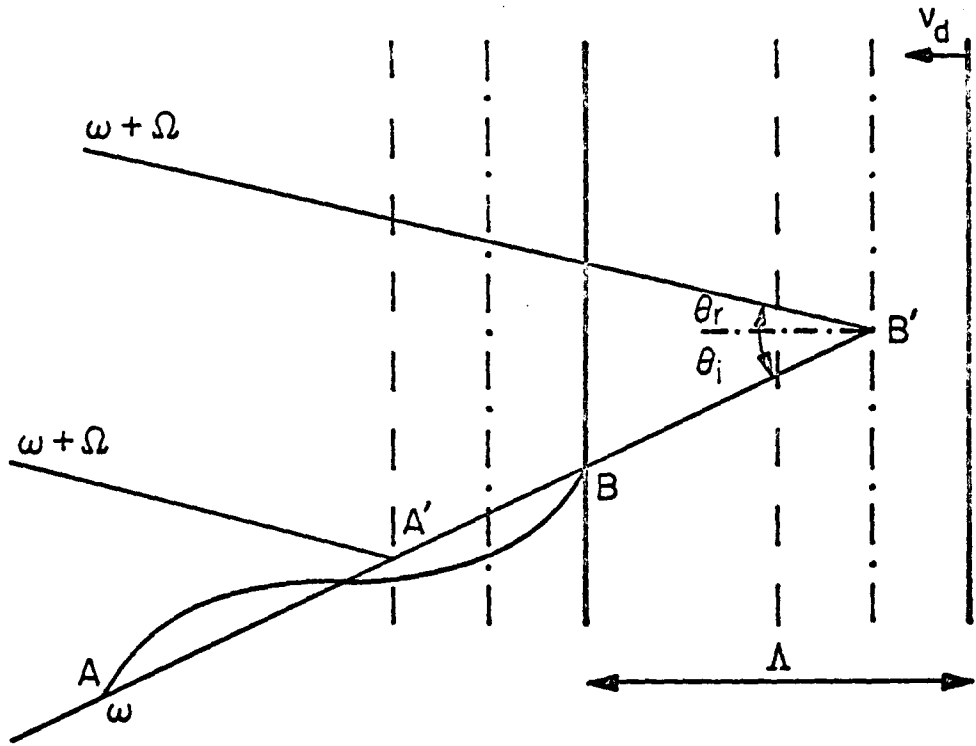

Fig. 8. Successive position of a disturbance front at different times. Bragg effect.  $AB = \lambda$

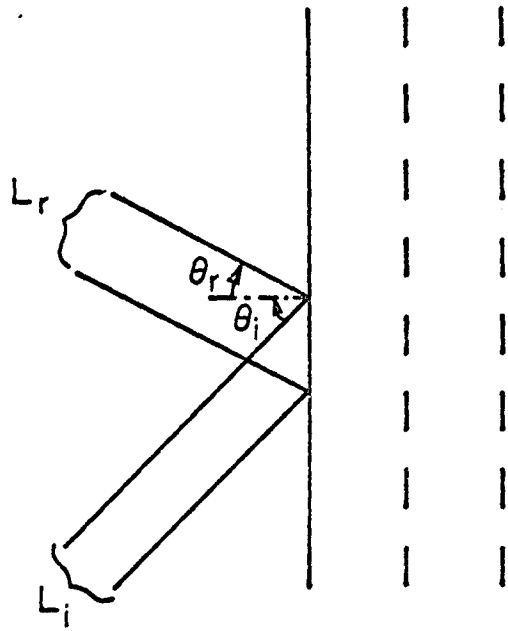

Fig. 9. Oblique incidence and reflection

For a slab of thickness  $L$  (see Fig. 7), if we write the field expressions in the two media and satisfy the boundary conditions, we get for the normal incidence

$R$  = reflection coefficient

$$= i\sqrt{\frac{\omega + \Omega}{\omega}} \tanh\left(\frac{\epsilon_1 L}{4} \sqrt{\frac{K_o (|K| - K_o)}{2}}\right)$$

$T$  = transmission coefficient

$$= \frac{1}{\cosh\left(\frac{\epsilon_1 L}{4} \sqrt{\frac{K_o (|K| - K_o)}{2}}\right)}$$

The reflected wave frequency is  $\omega + \Omega$  and the transmitted wave frequency is  $\omega$ .

When  $L \rightarrow \infty$ , then

$$T = 0$$

$$R = i\sqrt{\frac{\omega + \Omega}{\omega}}$$

and

$$|R|^2 = \frac{\omega + \Omega}{\omega}$$

## 2. Down-conversion

Let us suppose the parameters of the problem are such that

$$d_o \approx 0 \quad \Rightarrow \quad \delta^2 + \kappa^2 = \beta_o^2$$

$$d_{-1} \approx 0 \quad \Rightarrow \quad \delta^2 + (\kappa - K)^2 = \beta_{-1}^2$$

This occurs if

$$K^2 - 2K\sqrt{\beta_o^2 - \delta^2} = K_o^2 - 2K_o\beta_o \quad (2E.9)$$

Then  $E_{-1}$  will be of the order of  $E_o$  and following the same method used in the up-conversion case, we get

$$\kappa = k_{zo} \pm \epsilon_1 \frac{\beta_o \beta_{-1}}{4k_{zo}} \sqrt{\frac{k_{zo}}{k_{zo} - K}}$$

$$\frac{P_{-1}}{P_o} = \left(\frac{\omega - \Omega}{\omega_o}\right)^2 \left| \frac{k_{zo}}{k_{zo} - K} \right|$$

$$\frac{P_{-1} S_r}{P_o S_i} = \frac{\omega - \Omega}{\omega}$$

and for the slab at normal incidence (Fig. 7)

$$R = i \sqrt{\frac{K + K_o}{K - K_o}} \tanh \left( \frac{\epsilon_1 L}{8} \sqrt{K^2 - K_o^2} \right)$$

$$T = \frac{1}{\cosh \left( \frac{\epsilon_1 L}{8} \sqrt{K^2 - K_o^2} \right)}$$

For  $K < K_o$  the reflection and transmission coefficients become

$$R = i \sqrt{\frac{K + K_o}{K_o - K}} \tanh \frac{\epsilon_1 L}{8} \sqrt{K_o^2 - K^2}$$

$$T = \frac{1}{\cos \left( \frac{\epsilon_1 L}{8} \sqrt{K_o^2 - K^2} \right)}$$

and if the slab thickness is such that

$$\frac{\epsilon_1 L}{8} \sqrt{K_o^2 - K^2} = \pi \left( p + \frac{1}{2} \right)$$

where  $p$  is an integer, then  $R$  and  $T \rightarrow \infty$ . This means that there is auto-oscillation and the slab will radiate, on one side, a wave of frequency  $\omega$  and on the other, a wave of frequency of  $\omega - \Omega$ .

### F. Dipole Radiation

We assume a disturbance propagating parallel to the dipole moment in the  $z$ -direction (Fig. 10).

#### 1. Magnetic dipole

The magnetic dipole will radiate a wave with an electric field parallel to the disturbance wave front

$$\underline{E} = E(\rho, z, t) \underline{e}_\phi$$

therefore the wave equation is identical to the T.E. equation 2A.7

$$\nabla^2 E - \mu_o \frac{\partial^2 \epsilon E}{\partial t^2} = 0 \quad (2F.1)$$

outside of the source volume.

Using the separation of variables method, we have

$$E(\rho, z, t) = X(\rho) Z(z, t)$$

and

$$z \frac{d}{d\rho} \left[ \frac{1}{\rho} \frac{d\rho X}{d\rho} \right] + X \frac{\partial^2 Z}{\partial z^2} - \mu_o X \frac{\partial^2 \epsilon Z}{\partial t^2} = 0$$

which can be separated in the two equations

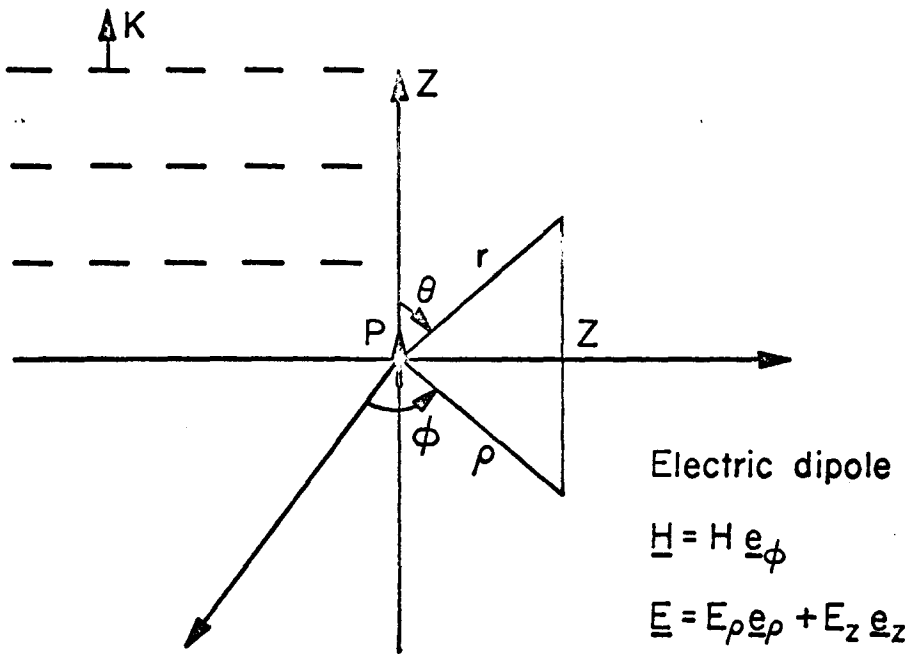
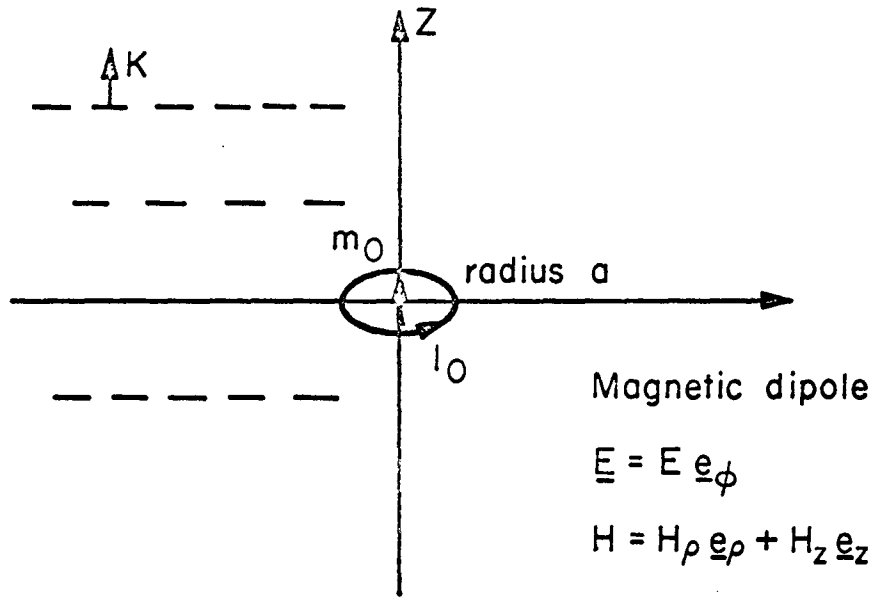

Fig. 10. Dipole in a space-time periodic medium

$$\frac{d}{d\rho} \left[ \frac{1}{\rho} \frac{d\rho X}{d\rho} \right] + \delta^2 X = 0 \quad (2F.2)$$

$$\frac{\partial^2 Z}{\partial z^2} - \mu_0 \frac{\partial^2 \epsilon Z}{\partial t^2} - \delta^2 Z = 0 \quad (2F.3)$$

where  $\delta$  is the separation variable.

The solution for  $X$  which satisfies the radiation condition at infinity and the finiteness condition at the origin is

$$X = B_1(\delta\rho)$$

where

$$B_n(\delta\rho) = J_n(\delta\rho) \quad \text{for } \rho < a$$

$$B_n(\delta\rho) = H_n^{(1)}(\delta\rho) \quad \text{for } \rho > a$$

Using Floquet's theorem the solution for  $Z$  is

$$Z(z,t) = \sum_n E_n e^{i(\kappa+nK)z - i(\omega+n\Omega)t}$$

with  $\kappa = \kappa(\delta)$ . So

$$XZ = \sum_n E_n B_1(\delta\rho) e^{i(\kappa+nK)z - i(\omega+n\Omega)t}$$

Here  $\delta$  is not fixed as it was in the half space problem, and to get the field we have to integrate over all the values of  $\delta$  using a weighting function (or, we can integrate over  $\kappa$ , because  $\kappa$  and  $\delta$  are related by the dispersion equation). So the electric field expression is

$$E = \int_{-\infty}^{+\infty} W(\kappa) \sum_n E_n B_1(\delta\rho) e^{i(\kappa+nK)z - i\omega_n t} d\kappa \quad (2F.4)$$

Putting the expression of  $\underline{E}$  into the wave equation 2F.1 we get the same dispersion equation 2B.5, and wave vector diagram (Fig. 2.3) as for the T.E. wave studied previously. So for each value of  $\kappa$ , there are many values for  $\delta$  and the field is finally given by

$$\underline{E} = e_{-\phi} \sum_q \sum_n \int_{-\infty}^{\infty} W_q(\kappa) E_{nq}(\kappa) B_1(\delta_q \rho) e^{i(\kappa+nK)z - i\omega_n t} d\kappa \quad (2F.5)$$

with  $\delta_q = \delta_q(\kappa)$ . The magnetic field can be determined from

$$\nabla \times \underline{E} = -\mu_0 \frac{\partial \underline{H}}{\partial t}$$

and we find

$$H_{\rho} = -\frac{1}{\mu_0} \sum_q \sum_n e^{-i\omega_n t} \int_{-\infty}^{\infty} \frac{\kappa+nK}{\omega_n} W_q(\kappa) E_{nq}(\kappa) B_1(\delta_q \rho) e^{i(\kappa+nK)z} d\kappa \quad (2F.6)$$

$$H_z = \frac{i}{\mu_0} \sum_q \sum_n e^{-i\omega_n t} \int_{-\infty}^{\infty} \frac{\delta_q}{\omega_n} W_q(\kappa) E_{nq}(\kappa) B_0(\delta_q \rho) e^{i(\kappa+nK)z} d\kappa \quad (2F.7)$$

All the  $\delta_q(\kappa)$  are known functions of  $\kappa$  and can be found from the dispersion equation or the wave vector diagram. The weighting functions  $W_q(\kappa)$  are determined from Ampere's law at the source (i.e., dipole).

At the source we have

$$[H_z(\rho > a) - H_z(\rho < a)]_{\rho \rightarrow a} = -I_0 \delta(z) e^{-i\omega t} \quad (2F.8)$$

where  $I_0$  = current in the loop of radius  $a$ , and  $\omega$  is its frequency.

Also

$$E_{\phi} |_{\rho \rightarrow a} \text{ is continuous}$$



The field expressions are

$$H_z(\rho > a) = \frac{i}{\mu_0} \sum_q \sum_n e^{-i\omega_n t} \int_{-\infty}^{\infty} \frac{\delta_q}{\omega_n} W_q E_{nq} H_0^{(1)}(\delta_q \rho) e^{i(\kappa+nK)z} dk$$

$$H_z(\rho < a) = \frac{i}{\mu_0} \sum_q \sum_n e^{-i\omega_n t} \int_{-\infty}^{\infty} \frac{\delta_q}{\omega_n} W'_q E_{nq} J_0(\delta_q \rho) e^{i(\kappa+nK)z} dk$$

$$E_\phi(\rho > a) = \sum_q \sum_n e^{-i\omega_n t} \int_{-\infty}^{\infty} W_q E_{nq} H_1^{(1)}(\delta_q \rho) e^{i(\kappa+nK)z} dk$$

$$E_\phi(\rho < a) = \sum_q \sum_n e^{-i\omega_n t} \int_{-\infty}^{\infty} W'_q E_{nq} J_1(\delta_q \rho) e^{i(\kappa+nK)z} dk$$

and the weighting functions are not the same for  $\rho > a$  and  $\rho < a$ .

The continuity equation gives

$$W_q H_1^{(1)}(\delta_q a) = W'_q J_1(\delta_q a)$$

and from Ampere's law (equation 2F.8) we get

$$\begin{aligned} \lim_{\rho \rightarrow a} \sum_q \sum_n \int_{-\infty}^{\infty} [W_q H_0^{(1)}(\delta_q \rho) - W'_q J_0(\delta_q \rho)] \frac{\delta_q}{\omega_n} E_{nq} e^{i(\kappa+nK)z - i\omega_n t} dk \\ = i\mu_0 I_0 \delta(z) e^{-i\omega t} \end{aligned}$$

Replacing  $W'_q$  by its expression function of  $W_q$ , and taking the limit  $\rho \rightarrow a$ , we obtain

$$\begin{aligned} \sum_q \sum_n \int_{-\infty}^{\infty} W_q \frac{H_0^{(1)}(\delta_q a) J_1(\delta_q a) - H_1^{(1)}(\delta_q a) J_0(\delta_q a)}{J_1(\delta_q a)} \delta_q \frac{E_{nq}}{\omega_n} e^{i(\kappa+nK)z - i\omega_n t} \\ = i\mu_0 I_0 \delta(z) e^{-i\omega t} \end{aligned}$$

This reduces to

$$\sum_q \sum_n \frac{W_q E_{nq}}{J_1(\delta_q a)} e^{i(\kappa + nK)z - i\omega_n t} d\kappa = -\frac{1}{2} \pi \mu_0 a I_0 \delta(z) e^{-i\omega t}$$

where we used the following properties of the Bessel functions:

$$H_0^{(1)} J_1 - H_1^{(1)} J_0 = i(Y_0 J_1 - Y_1 J_0)$$

$$J_1 = -J'_0$$

$$Y_1 = -Y'_0$$

$$\text{Bessel equation Wronskian} = \frac{2i}{\pi x}$$

Finally, taking  $a \rightarrow 0$  we get

$$\sum_q \sum_n \int_{-\infty}^{\infty} \frac{W_q}{\delta_q} E_{nq} e^{i(\kappa + nK)z - i\omega_n t} d\kappa = -\frac{\mu_0 m_0}{4} \delta(z) e^{-i\omega t} \quad (2F.9)$$

where  $m_0 = \pi a^2 I_0 = \text{magnetic moment}$ .

To solve this equality for  $W_q$  we write  $\delta(z)$  in an integral form

$$\delta(z) = \int_{-\infty}^{\infty} e^{i\kappa z} d\kappa$$

Then equation 2F.9 becomes

$$\int_{-\infty}^{\infty} \left[ \sum_q \sum_n \frac{W_q}{\delta_q} E_{nq} e^{in(Kz - \Omega t)} + \frac{\mu_0 m_0}{4} e^{i(\kappa z - \omega t)} \right] d\kappa = 0$$

and this is satisfied if

$$\sum_q \sum_n \frac{W_q}{\delta_q} E_{nq} e^{in(Kz - \Omega t)} = \mu_o \frac{m_o}{4}$$

This relation must be true for all values of  $z$  and  $t$ ,  
so we must have

$$\sum_q C_{nq} \alpha_q = 0 \quad \text{for } n \neq 0$$

$$\sum_q C_{oq} \alpha_q = -\frac{\mu_o m_o}{4}$$

where we took

$$\alpha_q = \frac{W_q}{\delta_q} E_{oq}$$

$$C_{nq} = \frac{E_{nq}}{E_{oq}} \quad (\text{defined by equation 2B.8})$$

or in a matrix form

$$||C|| \cdot |\alpha| = |m|$$

and

(2F.10)

$$|\alpha| = ||C||^{-1} \cdot |m|$$

where

$$||C|| = \text{matrix with elements } C_{nq}$$

$$|\alpha| = \text{column vector with elements } \alpha_q$$

$$|m| = \text{column vector with elements } \begin{cases} m_n = 0 & \text{for } n \neq 0 \\ m_n = -\frac{\mu_o m_o}{4} & \text{for } n = 0 \end{cases}$$

Equation 2F.10 determines  $|\alpha|$  and the field expression is completely determined by

$$E(\rho > a) = \sum_q \sum_n e^{-i\omega_n t} \int_{-\infty}^{\infty} \alpha_q(\kappa) \delta_q(\kappa) C_{nq}(\kappa) H_1^{(1)}(\delta_q \rho) e^{i(\kappa+nK)z} d\kappa \quad (2F.11)$$

The integral can be evaluated in the far field by the steepest descent method (see later).

## 2. Electric dipole (Fig. 10)

The field has the components

$$\begin{aligned} \underline{H} &= H \underline{e}_\phi \\ \underline{E} &= E_\rho \underline{e}_\rho + E_z \underline{e}_z \end{aligned}$$

Maxwell's equations outside of the source volume give

$$\nabla \times \underline{H} = \frac{\partial \epsilon \underline{E}}{\partial t} \implies \begin{cases} -\frac{\partial H}{\partial z} = \frac{\partial \epsilon E_\rho}{\partial t} \\ \frac{1}{\rho} \frac{\partial}{\partial \rho} (\rho H) = \frac{\partial \epsilon E_z}{\partial t} \end{cases} \quad (2F.12)$$

$$\nabla \times \underline{E} = -\mu_0 \frac{\partial \underline{H}}{\partial t} \implies \frac{\partial E_z}{\partial \rho} - \frac{\partial E_\rho}{\partial z} = \mu_0 \frac{\partial H}{\partial t} \quad (2F.13)$$

Using Floquet's theorem, and following the same method used for the magnetic dipole problem, we can write

$$\underline{H} = \underline{e}_\phi \sum_q \sum_n \int_{-\infty}^{\infty} W_q H_{nq} H_1^{(1)}(\delta_q \rho) e^{i(\kappa+nK)z - i\omega_n t} d\kappa$$

$$\underline{E} = \sum_q \sum_n \int_{-\infty}^{\infty} W_q (-iE_{nqz} H_0^{(1)}(\delta_q \rho) \underline{e}_z + E_{nq\rho} H_1^{(1)}(\delta_q \rho) \underline{e}_\rho) \times e^{i(\kappa+nK)z - i\omega_n t} d\kappa$$

Putting these expressions in 2F.12 and 2F.13, equating the terms with the same frequency, and eliminating  $H_{nq}$  we get

$$D_{nq} E_{nq\rho} + E_{n+1,q\rho} + E_{n-1,q\rho} + G_{nq} E_{nqz} = 0$$

$$D'_{nq} E_{nqz} + E_{n+1,qz} + E_{n-1,qz} + G_{nq} E_{nq\rho} = 0$$

where  $D_{nq}$ ,  $D'_{nq}$  and  $G_{nq}$  are defined by 2B.14 and 2B.15. These equations are identical to the equation obtained for the T.M. field in Section II-B.2.

The weighting functions are determined by the source condition

$$\lim_{\rho \rightarrow 0} 2\pi\rho H_\phi = I$$

where  $I = -i\omega p \delta(z) e^{-i\omega t}$ , and  $p =$  dipole moment. This condition gives

$$\lim_{\rho \rightarrow 0} 2\pi\rho \sum_q \sum_n \int_{-\infty}^{\infty} W_q H_{nq} H_1^{(1)}(\delta_q \rho) e^{i(\kappa+nK)z - i\omega_n t} d\kappa = -i\omega p \delta(z) e^{-i\omega t}$$

Taking the limit  $\rho \rightarrow 0$  we get

$$\sum_q \sum_n \int_{-\infty}^{\infty} \frac{W_q}{\delta_q} H_{nq} e^{i(\kappa+nK)z - i\omega_n t} d\kappa = \frac{1}{4} \omega p \delta(z) e^{-i\omega t}$$

Writing  $\delta(z) = \int_{-\infty}^{\infty} e^{iKz} dK$ , this equation becomes

3. Asymptotic evaluation of the integral

Only the magnetic dipole field is studied in this section. The same method, using the corresponding dispersion equation, can be used for the electric dipole field.

The electric field is given by 2F.11

$$E = \sum_q \sum_n e^{-i\omega_n t} \int_{-\infty}^{\infty} \alpha_q \delta_q C_{nq} H_1^{(1)}(\delta_q \rho) e^{i(\kappa+nK)z} d\kappa$$

When  $\rho \rightarrow \infty$ ,

$$H_1^{(1)}(\delta_q \rho) \rightarrow -i \sqrt{\frac{2}{\pi \rho \delta_q}} e^{i\delta_q \rho - i \frac{\pi}{4}}$$

therefore, in the far field we have

$$E = -i \sqrt{\frac{2}{\pi r \sin \theta}} e^{-i \frac{\pi}{4}} \sum_q \sum_n \int_{-\infty}^{\infty} \delta_q^{1/2} \alpha_q C_{nq} e^{irF_q(\kappa) - i\omega_n t} d\kappa$$

where  $F_q(\kappa) = (\kappa+nK) \cos \theta + \delta_q \sin \theta$

$$r^2 = \rho^2 + z^2$$

and

$$\text{tg} \theta = \frac{\rho}{z}$$

Using the steepest descent method when  $r \rightarrow \infty$ , we find (see Appendix C)

$$E = -\frac{2i}{r \sin \theta} \sum_j \sum_q \sum_n \left( \frac{\delta_{qs}}{|\delta''_{qs}|} \right)^{1/2} \alpha_{qs} \times C_{nq}(\kappa_s) e^{-i\omega_n t + irF_{qs} - i \frac{\pi}{4} (1 - \text{sign} \delta''_{qs})}$$

where  $\alpha_{qs} = \alpha_q(\kappa_s)$ ,  $F_{qs} = F_q(\kappa_s)$

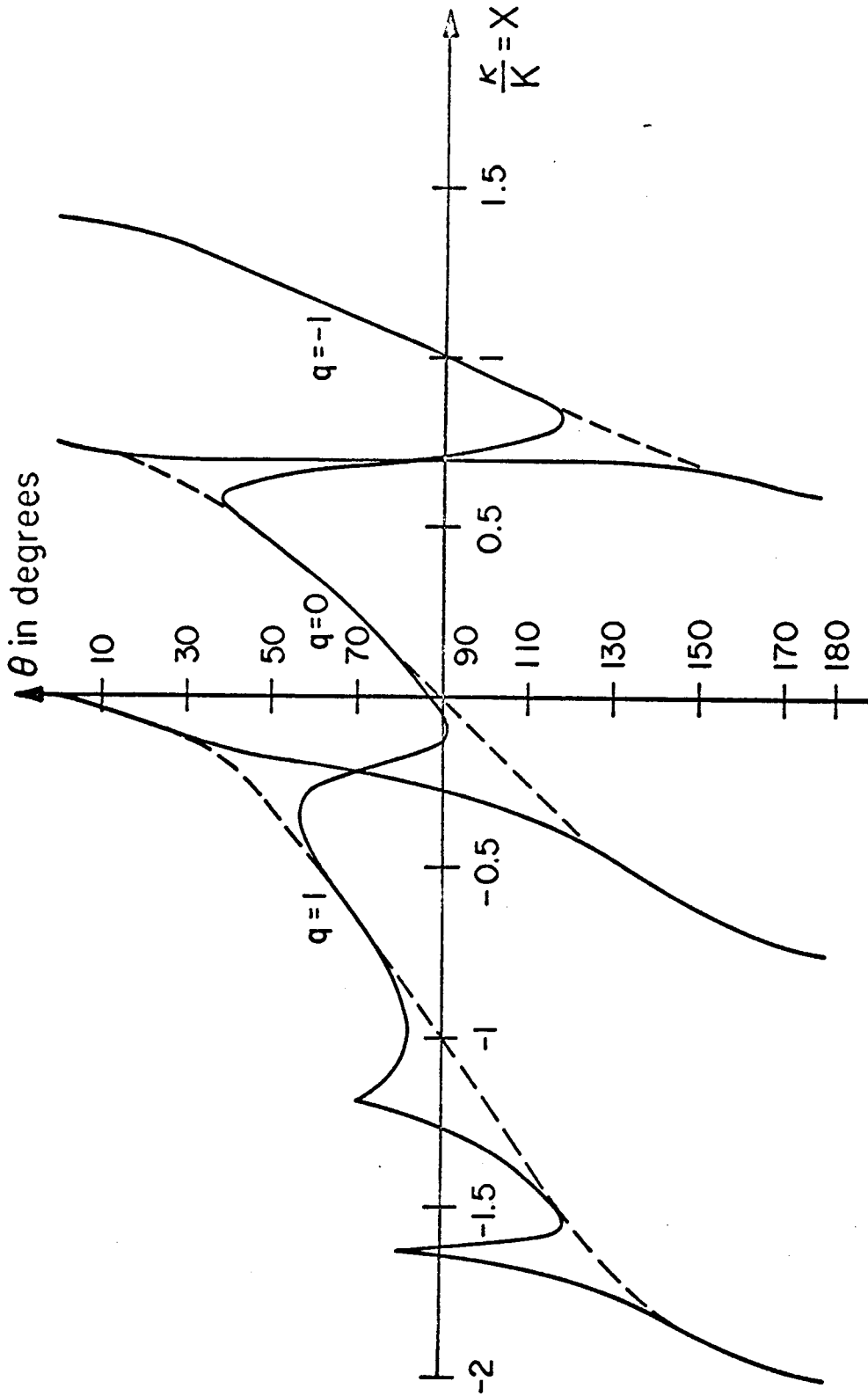

Fig. 11. Curve  $\theta = f(\kappa_s/K)$  for a dielectric  $R = 3.5$ ,  $\omega/\Omega = 2.5$ ,  $\epsilon_1 = 0.25$ . The dashed line corresponds to  $\epsilon_1 \rightarrow 0$

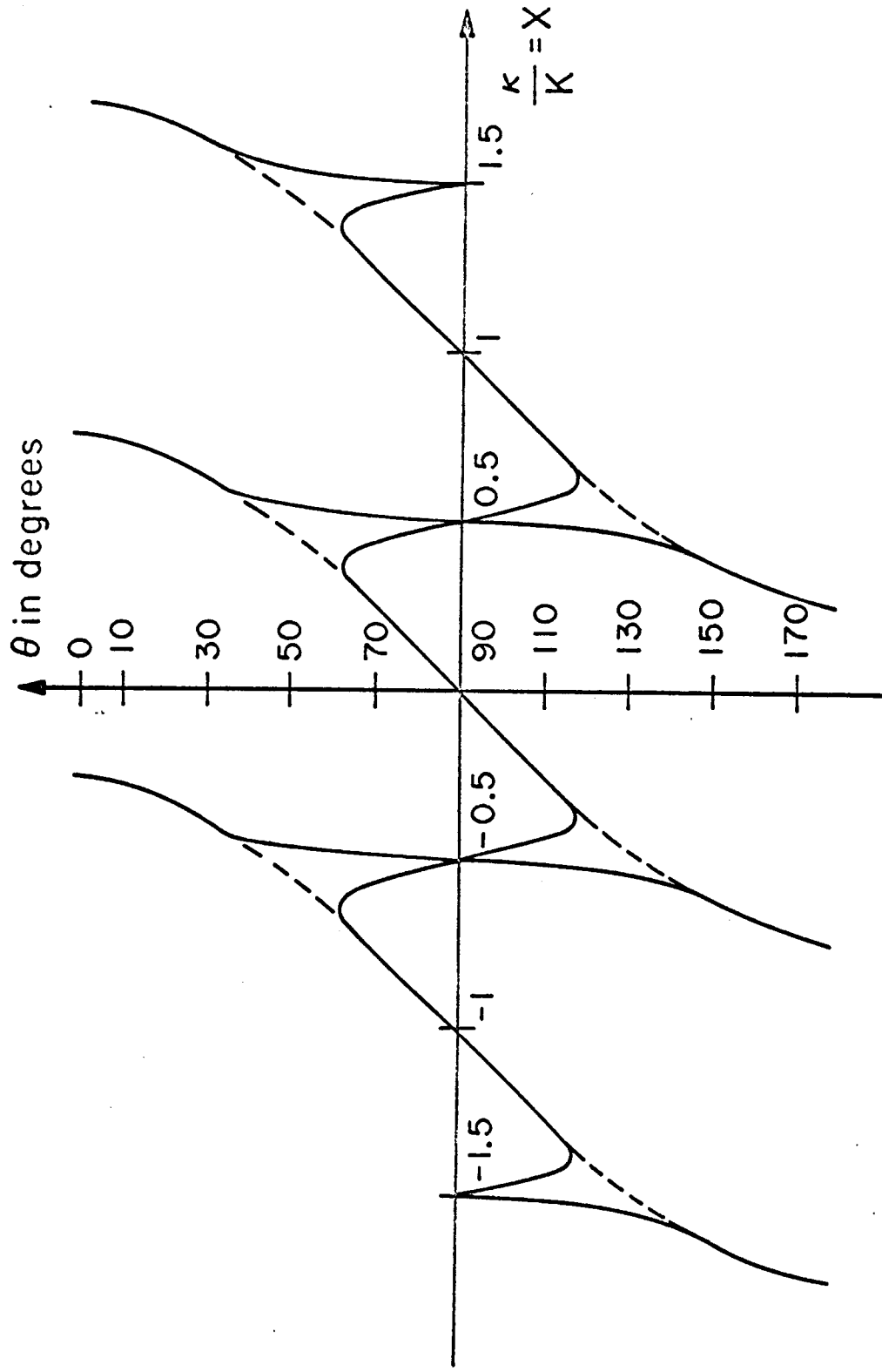

Fig. 12. Curve  $\theta = f(\kappa_s/K)$  for a dielectric  $v_d = 0$ ,  $\lambda/\Lambda = 1.4$ ,  $\epsilon_1 = 0.25$ . The dashed line corresponds to  $\epsilon_1 \rightarrow 0$



--The symmetry, relative to  $\theta = 90^\circ$ , is lost

--The number of saddle points per mode is not the same for all modes.

#### 4. Caustics

A very interesting effect appears when  $\epsilon_1 \neq 0$  and this is the existence of inflection points, near the interaction region between two modes (i.e., the stop band), in the wave vector diagram. This corresponds to extremas on the curve  $d\delta/dk$ .

At an inflection point  $\delta'' = 0$ , and the field given by equation 2F.14 is very large. This is a focalization and radiation enhancement effect, due to the inhomogeneities of the medium, on a certain surface called "Caustic". In our problem the caustics are conical surfaces. For a detailed physical explanation, see Appendix C.

The slope of  $\delta(k)$  at the point where  $\delta'' = 0$  gives the caustic angle  $\theta_c$

$$\cotang \theta_c = \left. \frac{d\delta}{dk} \right|_{\text{at inflection point}}$$

From Figs. 4 and 12, which correspond to a stationary disturbance we find

$$\theta_c = 62^\circ \text{ and } \theta_c = 118^\circ \text{ for all the modes}$$

If  $\lambda/\Lambda$  or  $\epsilon_1$  changes we may get more or less caustics.

For a moving disturbance (Figs. 3 and 11) we find

$$\theta_c = 120^\circ \text{ for the mode } q = -1$$

$\theta_c = 37^\circ$  and  $\theta_c = 93^\circ$  for the mode  $q = 0$

$\theta_c = 56^\circ$ ,  $\theta_c = 82^\circ$  and  $\theta_c = 120^\circ$  for  $q = 1$

5. Field amplitude and radiation pattern

The magnetic dipole field expression is

$$\underline{E} = \underline{e}_\phi \frac{-2i}{r \sin \theta} \sum_j \sum_q \sum_n \left( \frac{\delta_{qs}}{|\delta''_{qs}|} \right)^{1/2} \alpha_{qs} C_{nq}(\kappa_s) \times e^{-i\omega_n t + irF_{qs} - i \frac{\pi}{4} (1 - \text{sign } \delta''_s)}$$

Let us take

$$C'_{nq} = ||C||_{nq}^{-1}$$

then from 2F.10, we get

$$\alpha_q = -\frac{1}{4} \mu_o m_o C'_{oq}$$

So, for the  $n^{\text{th}}$  harmonic we get

$$|E_n|^2 = \left( \frac{\mu_o m_o}{2r \sin \theta} \right)^2 \sum_q \sum_j \frac{\delta_{qs}}{|\delta''_{qs}|} (C'_{oq} C_{nq})^2 + \left( \frac{\mu_o m_o}{2r \sin \theta} \right)^2 \sum_q \sum_j \sum_{m \neq q} \sum_{p \neq j} \left( \frac{\delta_{qs} \delta_{ms}}{|\delta''_{qs} \delta''_{ms}|} \right)^{1/2} C'_{oq} C'_{om} C_{nq} C_{nm} e^{ir(F_{qs} - F_{ms})}$$

The second term in the expression of  $|E_n|^2$  is oscillatory and we can drop it if we average over  $r$ . So the average of the  $n^{\text{th}}$  harmonic field is

$$|E_n| = \frac{\mu_o m_o}{2r \sin \theta} \left[ \sum_q \sum_j \frac{\delta_{qs}}{|\delta''_{qs}|} (C'_{oq} C_{nq})^2 \right]^{1/2}$$

or

$$r^2 |E_n|^2 = \left( \frac{\mu_o m_o}{2 \sin \theta} \right)^2 \sum_q \sum_j \left( \frac{\delta_{qs}}{|\delta_{qs}''|} \right) (C'_{oq} C_{nq})^2$$

If  $\epsilon_1 \rightarrow 0$  then

$$C_{nq} = 0 \quad \text{for } n \neq 0$$

$$C_{oq} = 1$$

$$C'_{oq} C_{oq} = 1$$

$$\frac{\delta}{|\delta'''|} = \mu_o \epsilon_o \epsilon_r \omega^2 \sin^4 \theta$$

and there is only one mode and one saddle point. So

$$r^2 |E_n|^2 \Big|_{\epsilon_1 \rightarrow 0} = \left( \frac{\mu_o m_o}{2} \right)^2 \mu_o \epsilon_o \epsilon_r \omega^2 \sin^2 \theta$$

If we want to normalize the pattern such that for  $\epsilon_1 = 0$  we get  $r^2 |E_n|^2 = \sin^2 \theta$ , then the  $n^{\text{th}}$  harmonic pattern for  $\epsilon_1 \neq 0$  must be multiplied by a normalization factor equal to

$$\left[ \left( \frac{\mu_o m_o}{2} \right)^2 \mu_o \epsilon_o \epsilon_r \omega^2 \right]^{-1}$$

Then we get the pattern

$$G_n(\theta) = \left( \frac{\Omega}{\omega} \right)^2 \frac{1}{K_o^2 \sin^2 \theta} \sum_q \sum_j \frac{\delta_{qs}}{|\delta_{qs}''|} (C'_{oq} C_{nq})^2$$

Figure 12' gives the dipole pattern for a stationary disturbance with

$$\epsilon_1 = 0.25 \quad \text{and} \quad \frac{\lambda}{\Lambda} = 0.8$$

In Figs. 13 and 14 we present the patterns of the fundamental wave and the  $\omega + \Omega$  harmonic for

$$\epsilon_1 = 0.25 \quad , \quad \frac{\omega}{\Omega} = 2.5 \quad \text{and} \quad R = \frac{v_o}{v_d} = 3.5$$

The pattern for the  $\omega - \Omega$  harmonic is very small and was not plotted. Let us examine the features of these patterns:

1) Stationary disturbance

For  $\Lambda/\lambda = 1.25$  (Fig. 12<sup>a</sup>), there are four caustics at  $\theta_c = 43^\circ, 147^\circ, 82^\circ$  and  $98^\circ$ , and the pattern is symmetric relative to  $\theta = 90^\circ$ .

For  $\Lambda/\lambda = 0.71$  (wave-vector diagram on Fig. 4), there are only two caustics at  $\theta_c = 62^\circ$  and  $118^\circ$ .

For larger values of  $\Lambda/\lambda$  we get more caustics, and for smaller values of  $\Lambda/\lambda$  we might get no caustics. In fact, if  $\lambda \gg \Lambda$ , the e.m. wave will not see the disturbance, and no focusing effect occurs.

2) Moving disturbance

In Fig. 13 we present the fundamental pattern for

$$\epsilon_1 = 0.25, \quad \Lambda/\lambda = 0.71 \quad \text{and} \quad R = 3.5$$

The caustic angles are  $\theta_c = 94^\circ$  and  $\theta_c = 37^\circ$ . Comparing these values to the corresponding stationary disturbance caustic angles (i.e.,  $\theta_c = 118^\circ$  and  $\theta_c = 62^\circ$ ), we see that the moving disturbance pushed both caustics upward in the  $+z$  direction.

The fundamental mode contributes mostly to the fundamental wave (i.e., frequency  $\omega$ ) pattern. The other modes contribute less

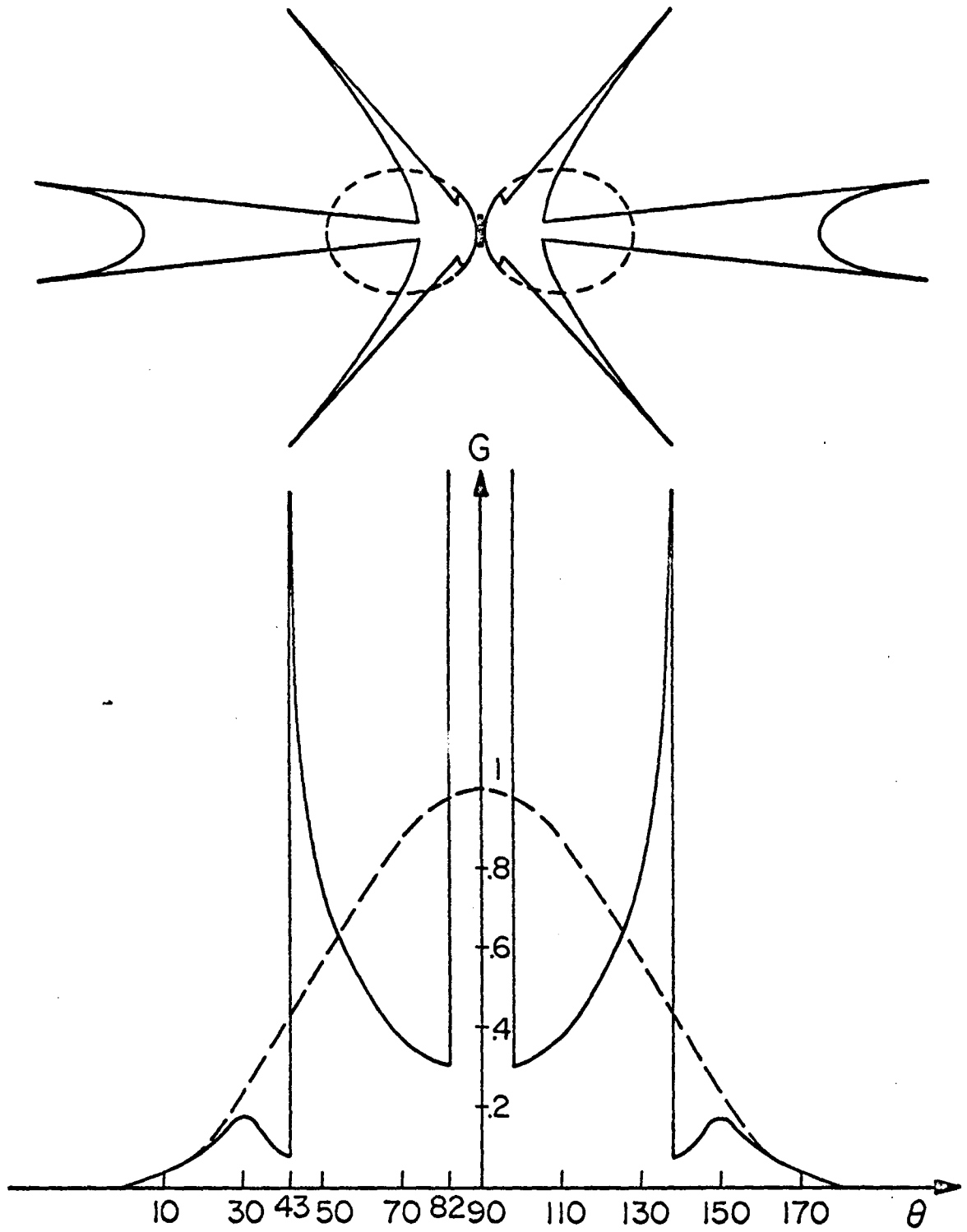

Fig. 12'. Radiation pattern of a dipole in a disturbed dielectric  
 $\omega/\Omega = 1000$ ,  $R = \infty$ ,  $v_d = 0$ ,  $\Lambda/\lambda = 1.25$ ,  $\epsilon_1 = 0.25$   
The dashed line corresponds to  $\epsilon_1 = 0$

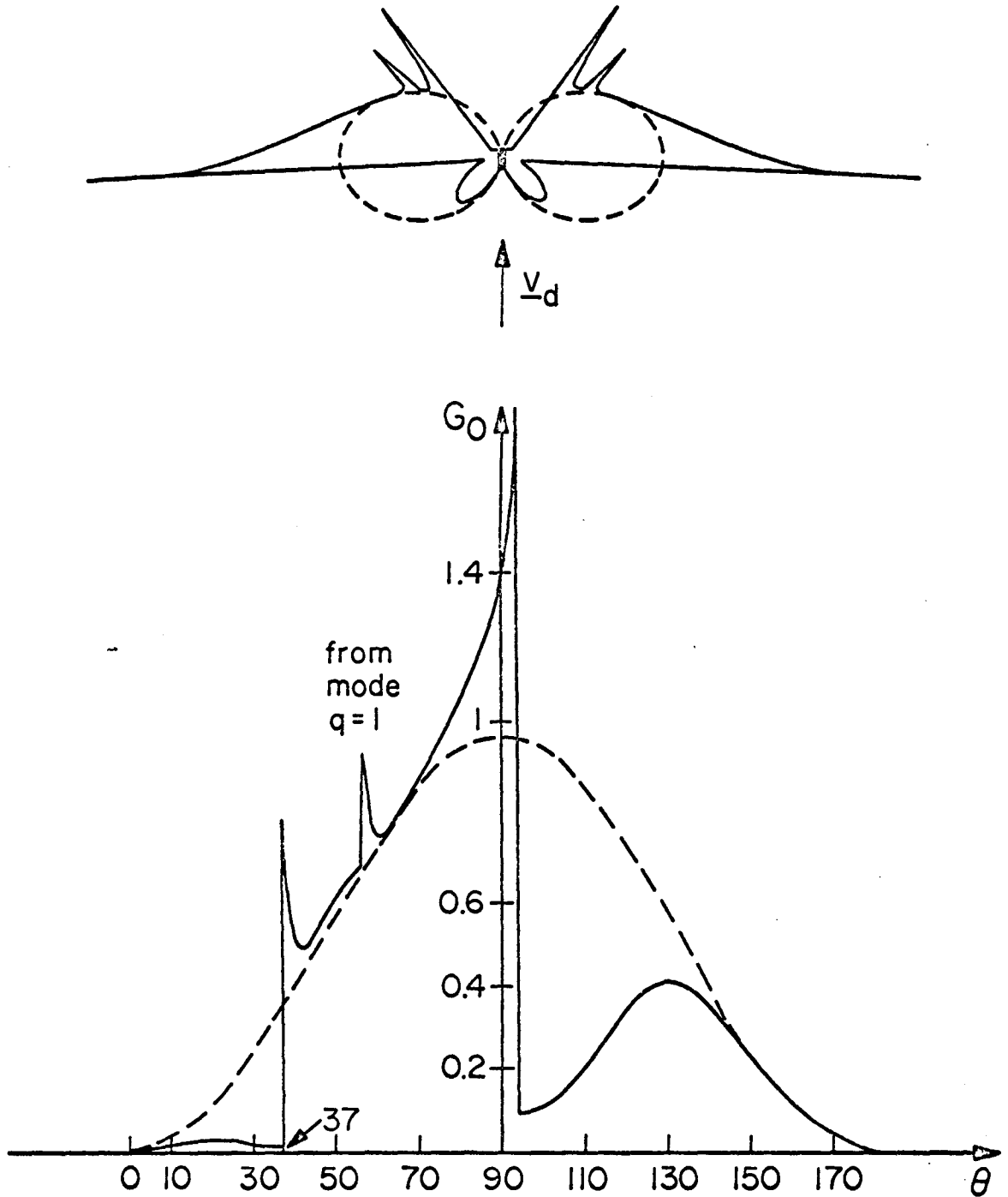

Fig. 13. Fundamental radiation pattern of a dipole in a disturbed dielectric:  $\omega/\Omega = 2.5$ ,  $R = 3.5$ ,  $\epsilon_1 = 0.25$ . The dashed line corresponds to  $\epsilon_1 = 0$

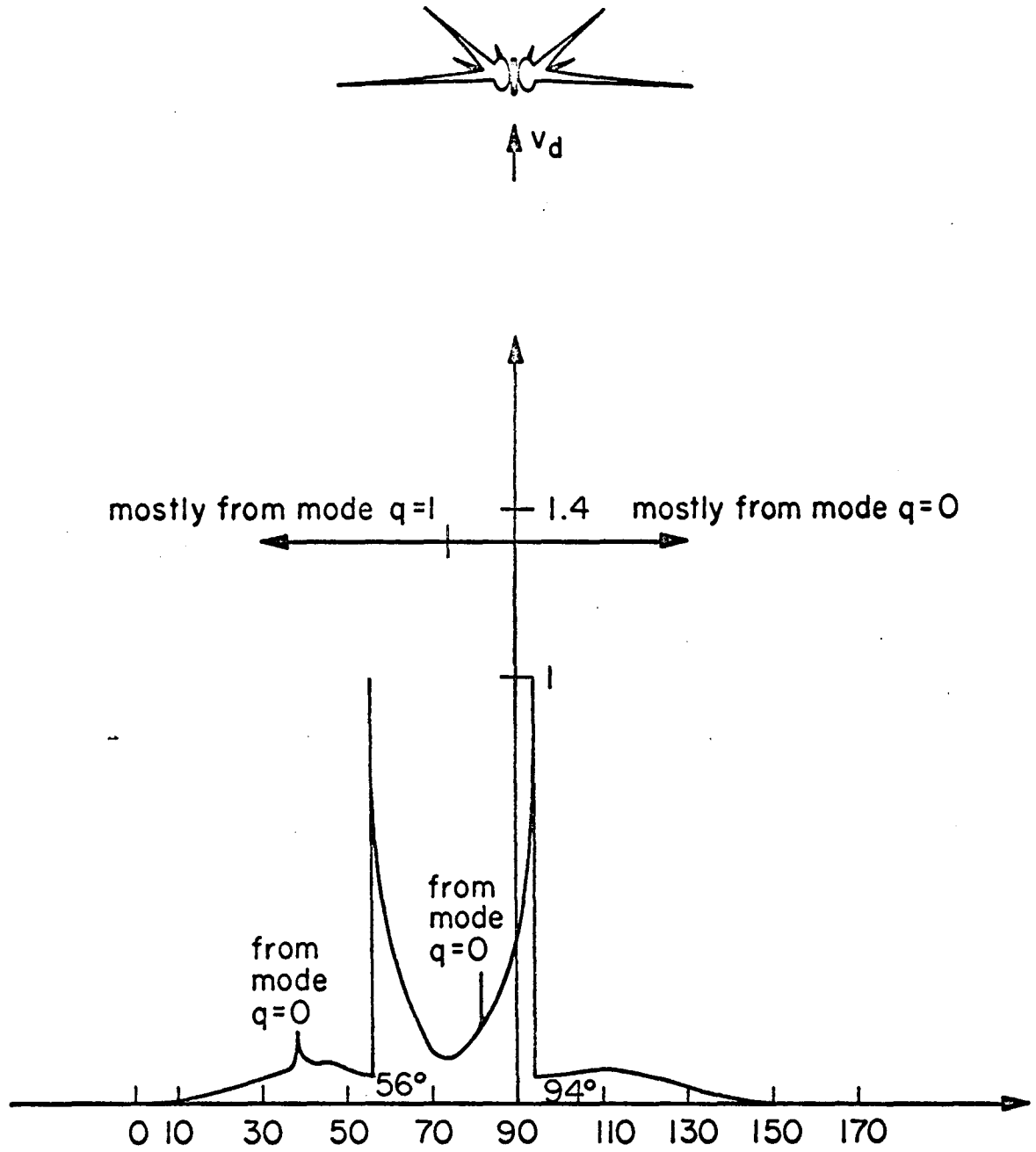

Fig. 14. Harmonic  $(\omega + \Omega)$  radiation pattern of a dipole in a disturbed dielectric:  $\omega/\Omega = 2.5$ ,  $R = 3.5$ ,  $\epsilon_1 = 0.25$

except near a caustic, and at this angle the fundamental pattern has a peak.

In Fig. 14 we give the pattern for the harmonic  $\omega + \Omega$ . The mode  $q = 1$  gives the peaks at  $\theta = 56^\circ$  and  $82^\circ$ , and the mode  $q = 0$  gives the peaks at  $\theta = 94^\circ$  and  $37^\circ$ .

### G. Different Approach

The problem of e.m. waves in a sinusoidally space-time periodic medium can be solved by a different method which deserves mentioning. This method will be studied in this section and compared to the one used up to now.

We use the Hertz vector wave equations 2A.12 and 2A.13

$$\nabla^2 \Pi + \epsilon \frac{\partial}{\partial z} \left( \frac{1}{\epsilon} \frac{\partial \Pi}{\partial z} \right) - \mu_0 \epsilon \frac{\partial^2 \Pi}{\partial t^2} = 0$$

$$\nabla^2 M - \mu_0 \frac{\partial}{\partial t} \left( \epsilon \frac{\partial M}{\partial t} \right) = 0$$

Making the following changes in the independent and dependent variables

$$\xi = z - \frac{\Omega}{K} t \qquad \eta = \frac{Kz}{\Omega} - \frac{K}{\Omega} \int_0^\xi f(\phi) d\phi$$

$$M = \left( \frac{K^2}{K^2 - k^2} \right)^{1/2} N \qquad \Pi = \left( \frac{\epsilon}{K^2 - k^2} \right)^{1/2} P$$

where

$$f(\phi) = \frac{K^2}{K^2 - k^2(\phi)}$$



$$k^2(\phi) = \mu_0 \epsilon(\phi) \Omega^2$$

$$\epsilon(\phi) = \epsilon_0 \epsilon_r [1 + \epsilon_1 \cos K\phi] \quad (\phi \text{ stands here for } z - \frac{\Omega t}{K})$$

we get

$$\frac{\partial^2 P}{\partial \xi^2} - \frac{K^4}{\Omega^2} \frac{k^2(\xi)}{(K^2 - k^2(\xi))^2} \frac{\partial^2 P}{\partial \eta^2} + \frac{K^2}{K^2 - k^2(\xi)} \nabla_2^2 P + F(\xi) P = 0 \quad (2G.1)$$

$$\frac{\partial^2 N}{\partial \xi^2} - \frac{K^4}{\Omega^2} \frac{k^2(\xi)}{(K^2 - k^2(\xi))^2} \frac{\partial^2 N}{\partial \eta^2} + \frac{K^2}{K^2 - k^2(\xi)} \nabla_2^2 N + G(\xi) N = 0 \quad (2G.2)$$

where

$$G(\xi) = \frac{k k'' + k'^2}{K^2 - k^2} + \left( \frac{k k'}{K^2 - k^2} \right)^2$$

$$F(\xi) = -\frac{3}{4} \left( \frac{\epsilon'}{\epsilon} \right)^2 + \frac{1}{2} \left( \frac{\epsilon''}{\epsilon} \right) - \frac{k k'}{K^2 - k^2} \frac{\epsilon'}{\epsilon} + \frac{k'^2 + k k''}{K^2 - k^2} + \left( \frac{k k'}{K^2 - k^2} \right)^2$$

and a prime means derivation relative to  $\xi$ .

The equations for P and N are similar, and we will study only the N equation.

The separation of variables method can be used to solve the N equation (this is the objective of all the above transformations).

Writing

$$N(\xi, \eta, x, y) = Y_1(\eta) Y_2(x, y) Y_3(\xi)$$

and using  $\gamma$  and  $\delta$  as separation variables, we get

$$\frac{d^2 Y_1}{d\eta^2} + \gamma^2 Y_1 = 0 \quad (2G.3)$$

$$\nabla_2^2 Y_2 + \delta^2 Y_2 = 0 \quad (2G.4)$$

$$\frac{d^2 Y_3}{d\xi^2} + J(\xi) Y_3 = 0 \quad (2G.5)$$

where  $J(\xi) = \frac{K^4}{\Omega^2} \left( \frac{k}{K^2 - k^2} \right)^2 \gamma^2 - \frac{K^2}{K^2 - k^2} \delta^2 + G(\xi)$

and  $J(\xi) =$  periodic function of  $\xi$

Taking  $\psi = \frac{K\xi}{2} = \frac{Kz - \Omega t}{2}$ , equation 2G.5 becomes

$$\frac{d^2 Y_3}{d\psi^2} + \left( a_0 + 2 \sum_{n=1}^{\infty} a_n \cos 2n\psi \right) Y_3 = 0 \quad (2G.6)$$

where we took

$$\frac{4}{K^2} J(\psi) = a_0 + 2 \sum_{n=1}^{\infty} a_n \cos 2n\psi$$

This is Hill's differential equation and its solution is Hill's function  $u(\psi; \gamma, \delta)$ . So

$$Y_3 = u(\psi; \gamma, \delta)$$

where  $\psi$  is the independent variable and  $\gamma$  and  $\delta$  are parameters.

The solutions for  $Y_1$  and  $Y_2$  are straightforward, and  $N$  is given by

$$N = u(\psi; \gamma, \delta) e^{i\delta x + i\gamma t}$$

in Cartesian coordinates with no  $y$  dependence, or

$$N = u(\psi; \gamma, \delta) e^{i\gamma t} B_0(\delta \rho)$$

in polar coordinates with axial symmetry ( $B_0$  = Bessel function).

Hill's function can be written under a Floquet form [22]

$$u(\psi; \delta, \gamma) = \sum_{n=0}^{\infty} C_n(\beta) e^{\pm i\beta\psi \pm i2n\psi}$$

where  $C_n$  are parameters and  $\beta$  is the Hill exponent which is given by

$$\sin^2 \frac{\pi\beta}{2} = \Delta(0) \sin^2 \frac{\pi\sqrt{a_0}}{2}$$

where

$$\Delta(0) = \text{Det} \|\Delta\|$$

$$\|\Delta\| = \text{matrix with elements} \begin{cases} \Delta_{mn} = 1 & \text{if } m = n \\ \Delta_{mn} = \frac{a_{m-n}}{a_0 - 4m^2} & \text{if } m \neq n \end{cases}$$

$$a_i = \text{coefficients in Hill's equation (2G.6)}$$

### 1. Half Space

$N$  is given by

$$N(\xi, \eta, x) = u(\psi; \gamma, \delta) e^{i\delta x + i\gamma\eta} = \sum_n C_n(\beta) e^{\pm i(2n+\beta)\psi + i\gamma\eta + i\delta x}$$

or

$$N(x, z, t) = \sum_n C_n(\beta) e^{\pm in(Kz - \Omega t) \pm i \frac{\beta}{2}(Kz - \Omega t) + i\delta x + i\gamma\eta}$$

Developing  $e^{i\gamma\eta}$  in a Fourier series, and as the time dependence must be of the form  $e^{i(\omega + \ell\Omega)t}$ , we get

$$N(x, z, t) = \sum_q \sum_{\ell} A_{\ell q} e^{i(\kappa_q + \ell K)z - i(\omega + \ell\Omega)t + i\delta x}$$

where

$$\kappa_q = \frac{\gamma_q + \omega}{\Omega} K$$

and  $\gamma_q$  is determined from the system of equations

$$\pm \frac{\beta\Omega}{2} = \omega + q\Omega + \frac{\gamma_q R^2}{\sqrt{(R^2 - 1)^2 - \epsilon_1^2}}$$

(2G.7)

$$\sin^2 \frac{\pi\beta}{2} = \Delta(0) \sin^2 \frac{\pi\sqrt{a_0}}{2}$$

From these two equations we can eliminate  $\beta$  and get  $\gamma_q(\delta)$  or  $\kappa_q(\delta)$ .

## 2. Dipole Radiation

For the magnetic dipole we have

$$N = u(\psi; \gamma, \delta) e^{i\gamma\eta} B_0(\delta\rho) = u(\psi; \beta) e^{i\gamma(\beta)\eta} B_0(\delta\rho)$$

This is an elementary solution and we must integrate over all values of  $\beta$  to get the total field, so

$$N = \int_{-\infty}^{\infty} w(\beta) u(\psi; \beta) e^{i\gamma(\beta)\eta} B_0(\delta\rho) d\beta$$

where  $w(\beta)$  is a weighting function and  $\delta = \delta(\beta)$ . The magnetic field can be found from

$$\underline{H} = -\frac{1}{\mu_0} \nabla \times \nabla \times \underline{M} = -\frac{1}{\mu_0} \nabla \times \nabla \times \left( \frac{K}{\sqrt{K^2 - k^2(\xi)}} \underline{N e_z} \right)$$

The magnetic field must be such that:

--  $H_\phi$  is continuous at  $\rho = a$  (see Fig. 10)

$$-- [H_z(\rho > a) - H_z(\rho < a)]_{\rho \rightarrow a} = - I_0 \delta(z - z_0) e^{-i\omega t}$$

-- H finite at the origin

-- H satisfies the radiation condition at infinity

where  $z_0$  is the dipole position on the z-axis ( $z_0 = 0$  if the dipole is at the origin).

From these conditions, after long computation, we can determine  $w(\beta)$  and we get finally

$$M = \frac{i}{16\pi} \mu_0 m_0 K \sqrt{\frac{K^2 - k^2(\xi_0)}{K^2 - k^2(\xi)}} e^{-i\omega t} \int_{-\infty}^{\infty} u^*(\psi_0; \beta) u(\psi; \beta) \times H_0^{(1)}(\delta\rho) e^{i\gamma(\eta - \eta_0)} d\beta$$

where

$$\psi_0 = \frac{K}{2} \xi_0$$

$$\xi_0 = z_0 - \frac{\Omega}{K} t$$

$$\eta_0 = \frac{Kz_0}{\Omega} - \int_0^{\xi_0} \frac{K}{\Omega} f(\phi) d\phi$$

$m_0$  = dipole moment

and we used the Hill's functions orthogonality relation

$$\frac{1}{2\pi} \int_{-\infty}^{\infty} u^*(x_0; \beta) u(x; \beta) d\beta = \delta(x - x_0)$$

If  $v_d \rightarrow 0$  ( $\Omega \rightarrow 0$ ), we get

$$k(\xi) = 0$$

$$\psi = \frac{Kz}{2} = \frac{\pi z}{\Lambda}$$

$$\psi_0 = \frac{\pi z_0}{\Lambda}$$

$$\eta = \eta_0 = t$$

and

$$M = \frac{i}{8\pi} \mu_0 m_0 \int_{-\infty}^{\infty} u^* \left( \frac{\pi z_0}{\Lambda}; \beta \right) u \left( \frac{\pi z}{\Lambda}; \beta \right) H_0^{(1)}(\delta \rho) d\beta$$

which is the result found by Casey [11], with a difference of a factor  $i\omega$  because of the Hertz vector definition.

The Hertz vector method gives the field in terms of Hill's function, but it is rather a long method and it does not give a clear picture of the modes and the harmonics. This led us to use the first method in our study.

III. SPACE-TIME PERIODIC ISOTROPIC PLASMA

In this chapter we consider an isotropic plasma submitted to a propagating sinusoidal disturbance, which leads to a plasma density

$$N(z,t) = N_0 [1 + N_1 \cos(Kz - \Omega t)]$$

A. Wave in Infinite and Half-Space

1. TE waves (Fig. 1)

Maxwell, Newton and the continuity equations are

$$\begin{aligned} \nabla \times \underline{E} &= -\mu_0 \frac{\partial \underline{H}}{\partial t} & \nabla \times \underline{H} &= \epsilon_0 \frac{\partial \underline{E}}{\partial t} + Nq\underline{v} \\ \nabla \cdot \underline{H} &= 0 & \nabla \cdot \underline{E} &= \frac{1}{\epsilon_0} \rho \\ \nabla \cdot (Nq\underline{v}) + \frac{\partial \rho}{\partial t} &= 0 & m \frac{d\underline{v}}{dt} &= q\underline{E} \end{aligned}$$

and for the TE wave

$$\underline{E} = E(x,z,t) \underline{e}_y$$

Taking  $\underline{E} = \partial \underline{A} / \partial t$  it is straightforward to get the wave equation for

$$\underline{A} \quad (\underline{A} = A \underline{e}_y)$$

$$\nabla^2 A - \mu_0 \epsilon_0 \frac{\partial^2 A}{\partial t^2} - \mu_0 \epsilon_0 \omega_p^2(z,t) A = 0 \quad (3A.1)$$

where

$$\omega_p^2(z,t) = \omega_{p0}^2 [1 + N_1 \cos(Kz - \Omega t)] \quad (3A.2)$$

and

$$\omega_{p0}^2 = \frac{N_0 q^2}{m \epsilon_0}$$

Using Floquet's theorem and the superposition principle as we did in Chapter II, we can write

$$A = \sum_{n=-\infty}^{n=+\infty} A_n e^{i(\kappa+nK)z + i\delta x - i\omega_n t}$$

where

$$\omega_n = \omega + n\Omega$$

Putting the expression of A in equation 3A.1 and equating the elements of the same frequency, we get the system of equations

$$[\delta^2 + (\kappa+nK)^2 - \beta_n^2 + \beta_{po}^2] A_n + \frac{N_1}{2} \beta_{po}^2 (A_{n+1} + A_{n-1}) = 0 \quad (3A.3)$$

or

$$D_n A_n + A_{n+1} + A_{n-1} = 0 \quad (3A.4)$$

where

$$D_n = \frac{2}{N_1} \frac{1}{\beta_{po}^2} [\delta^2 + (\kappa+nK)^2 - \beta_n^2 + \beta_{po}^2] \quad (3A.5)$$

$$\beta_{po}^2 = \mu_o \epsilon_o \omega_{po}^2$$

$$\beta_n^2 = \mu_o \epsilon_o \omega_n^2 = \mu_o \epsilon_o (\omega + n\Omega)^2$$

To have a nontrivial solution, the determinant  $\Delta(\delta, \kappa, \omega)$  of this system must vanish

$$\Delta(\delta, \kappa, \omega) = \text{Det} \begin{pmatrix} \text{system} \\ 3A.4 \end{pmatrix} = 0$$

This is the dispersion equation.

Solving the dispersion equation we get the wave vector diagram  $\delta(\kappa)$ , or the Brillouin diagram  $\kappa(\omega)$ .



In Fig. 15, we plotted the wave vector diagram corresponding to

$$N_1 = 0.25 \quad , \quad \omega/\Omega = 2.5 \quad ,$$

$$\frac{\omega_p}{\omega} = 0.75 \quad , \quad R = \frac{K}{K_0} = \frac{c}{v_d} = 3.5$$

where

$c$  = e.m. wave velocity in vacuum

$v_p$  = disturbance velocity

The modes with index  $n$  , such that  $\omega + n\Omega < \omega_p$  , are cut off.

In Fig. 15, this corresponds to

$$n < \frac{\omega_p - \omega}{\Omega} = -0.51$$

or

$$n < 0$$

The wave vector diagram envelope is a hyperbola. Its analytic expression can be found by taking the limit  $N_1 \rightarrow 0$  .

If  $N_1 \rightarrow 0$  , the dispersion equation becomes (from equation 3A.3)

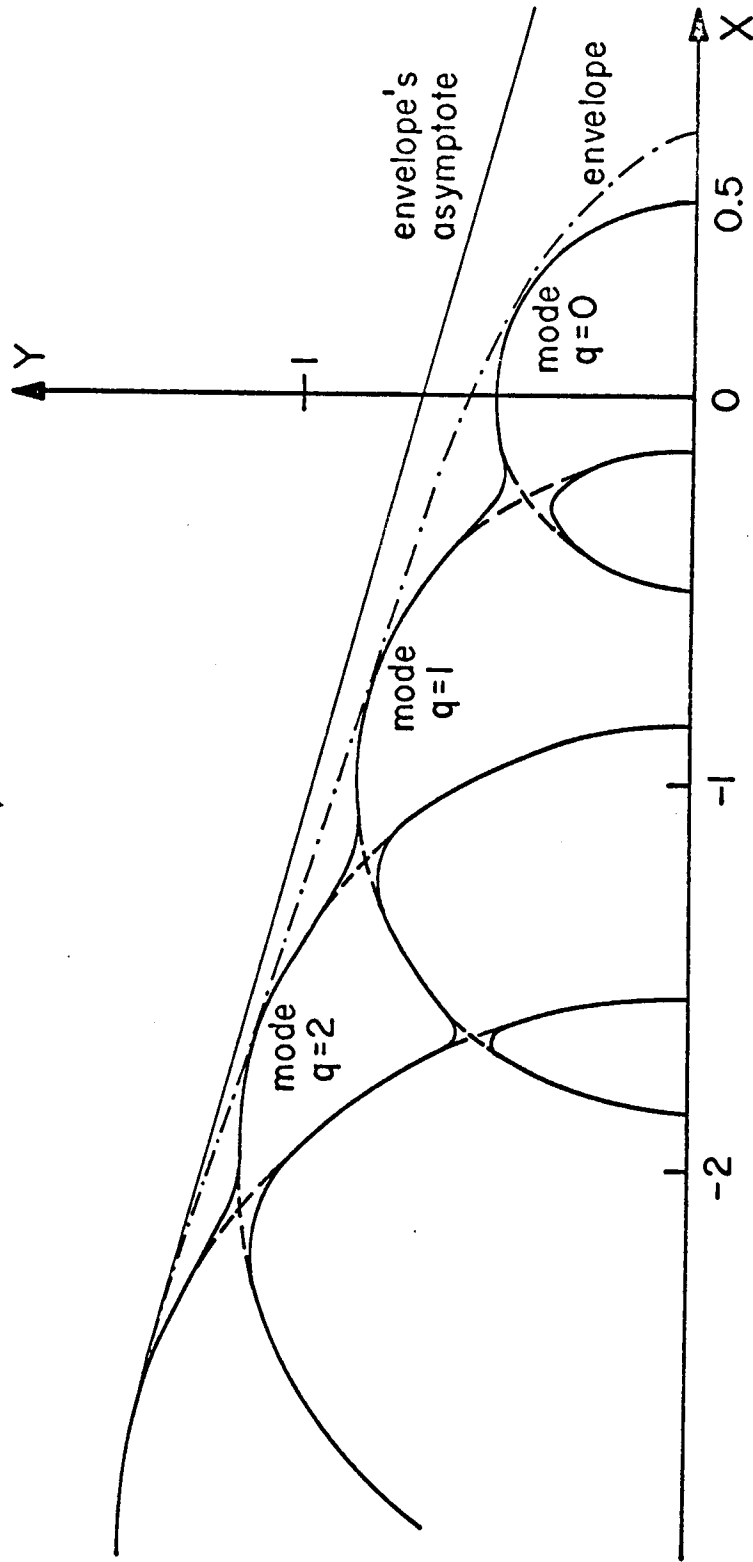

Fig. 15. Wave vector diagram:  $R = 3.5$ ,  $\omega/\Omega = 2.5$ ,  $\omega_p/\omega = 0.75$ ,  $N_1 = 0.25$ . The dashed line corresponds to  $N_1 = 0$

$$\delta^2 + (\kappa + nK)^2 - \beta_n^2 + \beta_{po}^2 = 0$$

or

$$Y^2 + (X + n)^2 = \frac{\omega_n^2 - \omega_{po}^2}{R^2 \Omega^2} \quad (3A.7)$$

where

$$Y = \frac{\delta}{K} \quad \text{and} \quad X = \frac{\kappa}{K}$$

This represents a family of circles centered at  $X = -n$  with radius  $\frac{1}{R\Omega} \left( \omega_n^2 - \omega_{po}^2 \right)^{1/2}$ . The envelope of this family can easily be found to be

$$Y^2 - \frac{\left(X - \frac{\omega}{\Omega}\right)^2}{R^2 - 1} = - \frac{\omega_{po}^2}{R^2 \Omega^2}$$

which is the equation of a hyperbola centered at

$$X = \frac{\omega}{\Omega}, \quad Y = 0$$

with an asymptote

$$Y = \frac{1}{\sqrt{R^2 - 1}} \left(X - \frac{\omega}{\Omega}\right)$$

For each value of  $\delta$  (or  $\kappa$ ) there is an infinite number of values for  $\kappa$  (or  $\delta$ ) which are not related by any simple relation because of the disturbance motion. So the expression of  $A$  must be

$$A = \sum_n \sum_q A_{nq} e^{i(\kappa_q + nK)z + i\delta x - i\omega_n t}$$

and as  $E = \frac{\partial A}{\partial t}$ , then

$$E = \sum_n \sum_q E_{nq} e^{i(\kappa_q + nK)z + i\delta x - i\omega_n t}$$

with

$$E_{nq} = -i\omega_n A_{nq}$$

and the relative amplitudes of the different harmonics are

$$\frac{E_{nq}}{E_{oq}} = \frac{\omega_n}{\omega_o} \frac{A_{nq}}{A_{oq}} = \frac{\omega_n}{\omega} C_{nq}$$

where  $C_{nq}$  is defined by 2B.8 with

$$D_{nq} = \frac{2}{N_1} \frac{1}{\beta_{po}^2} [\delta^2 + (\kappa + nK)^2 - \beta_n^2 + \beta_{po}^2]$$

Finally, the convergence condition

$$\lim_{n \rightarrow \infty} |D_n| > 2 \quad (\text{Poincare's theorem})$$

is always satisfied and there is no sonic region of divergence. This is a major difference from the dielectric case. Therefore, for the plasma, our study is valid even if the disturbance is due to an electromagnetic wave.

## 2. TM waves (Fig. 1)

Here we start directly from Maxwell, Newton and the continuity equations. Following the same method used in Chapter II for the dielectric, we can write

$$\underline{H} = \frac{e_y}{y} \sum_{n=-\infty}^{n=+\infty} H_n e^{i(\kappa+nK)z + i\delta x - i\omega_n t}$$

$$\underline{A} = \sum_{n=-\infty}^{n=+\infty} (A_{nx} \frac{e_x}{x} + A_{nz} \frac{e_z}{z}) e^{i(\kappa+nK)z + i\delta x - i\omega_n t}$$

and we get the infinite system of equations

$$\begin{aligned} & \left[ \frac{D_n D'_n - G_n^2}{G_n} + \frac{1}{G_{n+1}} + \frac{1}{G_{n-1}} \right] A_{nz} + \left[ \frac{D_n}{G_n} + \frac{D'_{n+1}}{G_{n+1}} \right] A_{n+1,z} \\ & + \left[ \frac{D_n}{G_n} + \frac{D'_{n-1}}{G_{n-1}} \right] A_{n-1,z} + \frac{1}{G_{n+1}} A_{n+2,z} + \frac{1}{G_{n-1}} A_{n-2,z} = 0 \end{aligned} \quad (3A.8)$$

This system is identical to 2B.16 except here we have

$$D_n = \frac{2}{N_1 \beta_{po}^2} [(\kappa+nK)^2 - \beta_n^2 + \beta_{po}^2]$$

$$D'_n = \frac{2}{N_1 \beta_{po}^2} [\delta^2 - \beta_n^2 + \beta_{po}^2]$$

$$G_n = \frac{2\delta}{N_1 \beta_{po}^2} (\kappa+nK)$$

The dispersion equation is

$$\Delta'(\delta, \kappa, \omega) = \text{Det} \begin{pmatrix} \text{system} \\ 3A.8 \end{pmatrix} = 0$$

The characteristic equation of the system 3A.8 when  $n \rightarrow \infty$

is

$$\rho^2 + A\rho + 1 = 0$$

where

$$A = \frac{2}{N_1 \beta_{po}^2} \frac{K^2}{K_o^2} (K^2 - K_o^2) n^2$$

and the convergence condition

$$\lim_{n \rightarrow \infty} |A| > 2$$

is always satisfied. (Even if  $K = K_o$  it can be shown that the

convergence condition is satisfied.) Therefore, for the TM wave too, there is no sonic region.

### 3. Reflection and transmission: half-space

The problem can be treated as in the case of the dielectric.

The only differences are:

- 1) We have to use the corresponding  $D_{nq}$  in all the expressions.
- 2) The solution of the system 3A.8 gives  $A_{nq}$  and we have

$$E_{nq} = -i\omega_n A_{nq}.$$

### B. Dipole Radiation

The method of solution is identical to the method used in Chapter II for the dielectric, and only the final results and patterns for the magnetic dipole are given here.

The magnetic dipole electric field is found to be

$$\underline{E} = \underline{e}_\phi \sum_q \sum_n \int_{-\infty}^{\infty} \alpha_q(\kappa) C_{nq}(\kappa) \delta_q(\kappa) \omega_n H_1^{(1)}(\delta_q \rho) e^{i(\kappa+nK)z - i\omega_n t} d\kappa$$

and the normalized average power pattern is

$$G_n(\theta) = \left(\frac{\Omega}{\omega}\right)^2 \frac{\omega_n^2}{\omega^2 - \omega_p^2} \frac{1}{K_o^2 \sin^2 \theta} \sum_q \sum_j \frac{\delta_{qs}}{|\delta''_{qs}|} (C'_{oq} C_{nq})^2$$

where the notations are the same as in Section IIF-3, except that

$$|\alpha| = \frac{i}{\omega} \|C\|^{-1} \cdot |m|$$

The factor  $i/\omega$  appears because the source condition applies to  $\underline{E}$ , not  $\underline{A}$ .

In Fig. 16 we plotted the curve of the angle  $\theta$  function of  $\kappa/K$  which corresponds to the wave vector diagram of Fig. 15. This curve gives, for each radiation angle  $\theta$ , the corresponding modes and saddle points.

In Figs. 17 and 18 we give the radiation patterns for the fundamental wave (frequency  $\omega$ ) and the first harmonic ( $\omega + \Omega$ ). As in the dielectric case, there are caustics and no symmetry relative to  $\theta = 90^\circ$ . The harmonic ( $\omega - \Omega$ ) is cut off because  $\omega - \Omega < \omega_{po}$ .

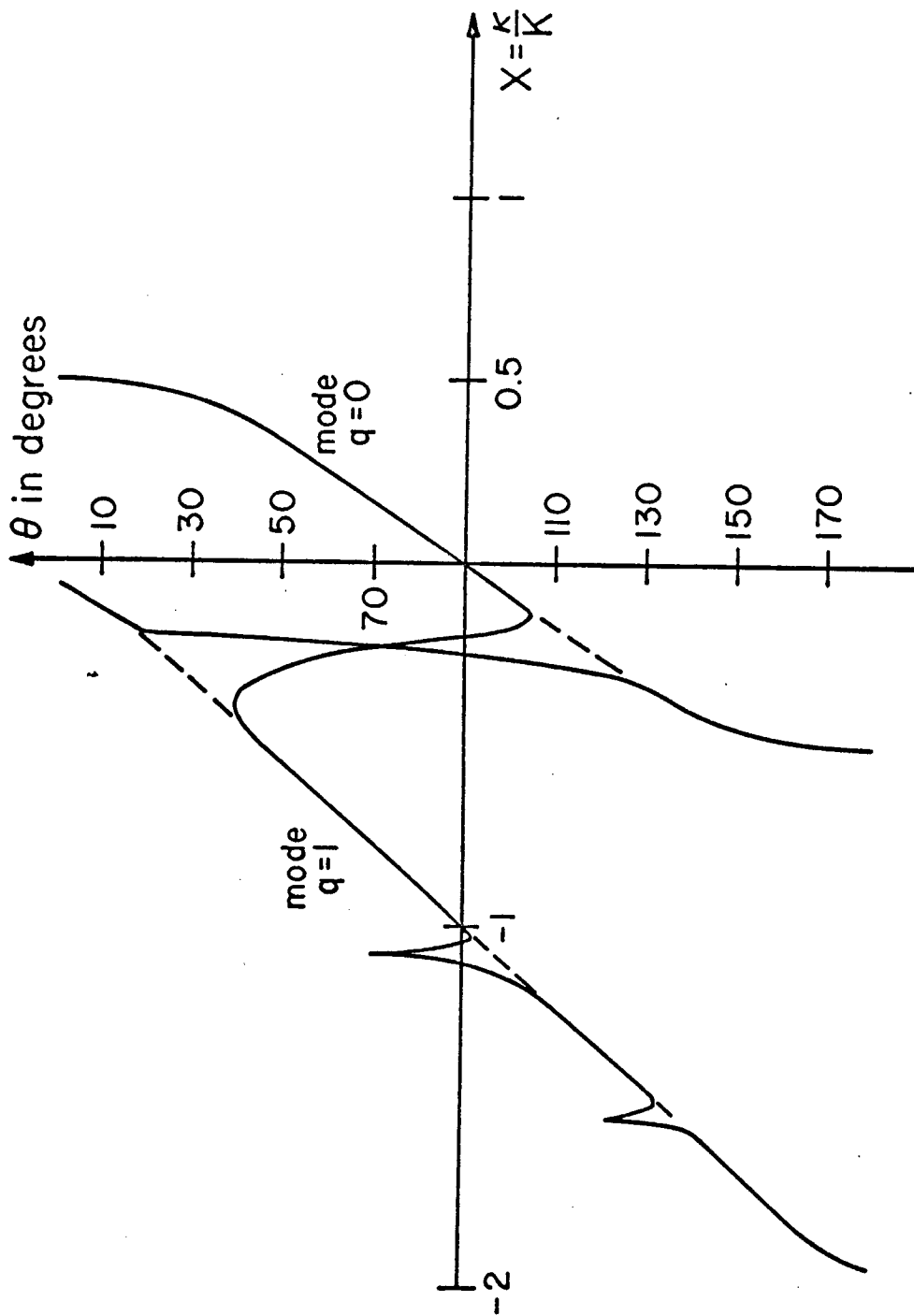

Fig. 16. Curve  $\theta = f(\kappa_s/K)$  for a plasma:  $R = 3.5$ ,  $\omega/\Omega = 2.5$ ,  $\omega/\omega_{p0} = 0.75$ ,  $N_1 = 0.25$ . The dashed line corresponds to  $N_1 \rightarrow 0$



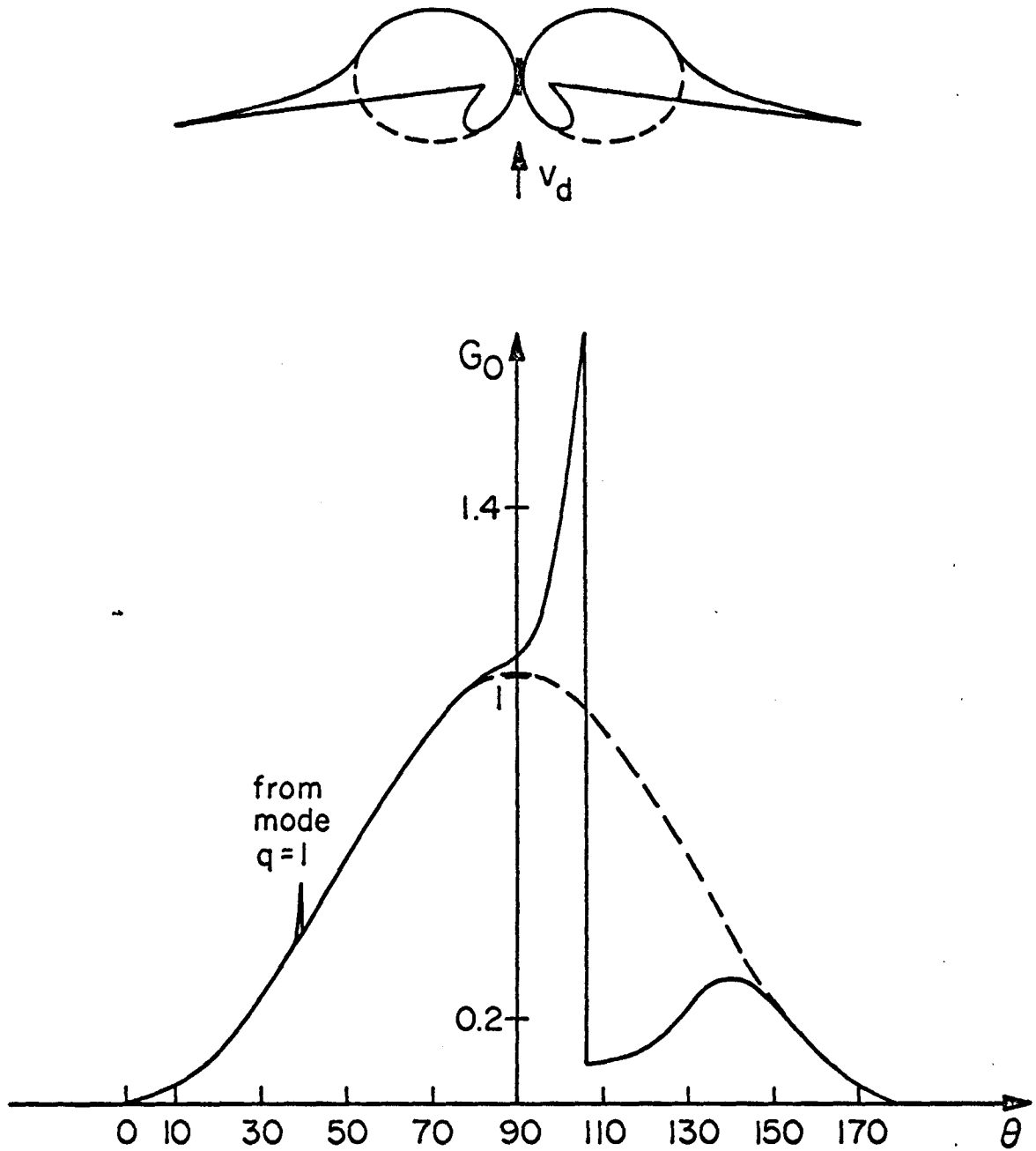

Fig. 17. Fundamental radiation pattern in a disturbed isotropic plasma  $\omega/\Omega = 2.5$ ,  $R = 3.5$ ,  $\omega_{po}/\omega = 0.75$ ,  $N_1 = 0.25$   
The dashed line corresponds to  $N_1 \rightarrow 0$ .

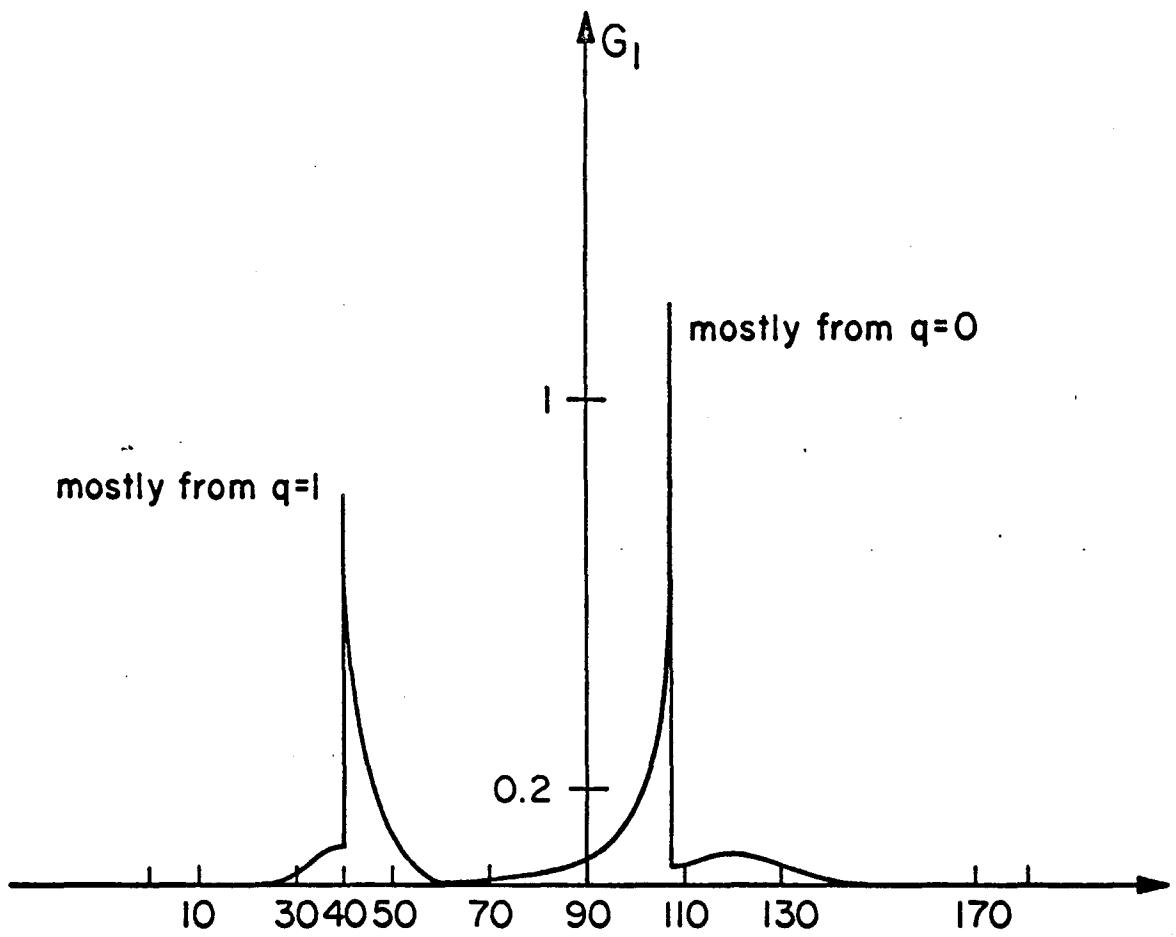
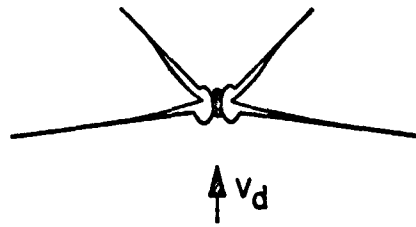

Fig. 18. Harmonic  $(\omega + \Omega)$  radiation pattern in a disturbed plasma  
 $\omega/\Omega = 2.5$ ,  $R = 3.5$ ,  $\omega_{p0}/\omega = 0.75$ ,  $N_1 = 0.25$ .

IV. SPACE-TIME PERIODIC UNIAXIAL MEDIA

The electric permittivity tensor of a uniaxial medium can be written

$$\epsilon = \|\epsilon\| = \begin{vmatrix} \epsilon' & 0 & 0 \\ 0 & \epsilon' & 0 \\ 0 & 0 & \epsilon''' \end{vmatrix}$$

in a Cartesian coordinate system, where the z axis is parallel to the optical axis. For the uniaxial plasma, the static magnetic field is taken parallel to the z-axis (Fig. 19).

We assume the medium to be perturbed by a sinusoidal disturbance propagating in the z-direction, such that

$$\epsilon' = \epsilon'(z,t) = \epsilon_0 \epsilon_r' [1 + \epsilon_1 \cos(Kz - \Omega t)]$$

$$\epsilon''' = \epsilon'''(z,t) = \epsilon_0 \epsilon_r''' [1 + \epsilon_3 \cos(Kz - \Omega t)]$$

for the dielectric, and

$$N(z,t) = N_0 [1 + N_1 \cos(Kz - \Omega t)]$$

for the plasma.

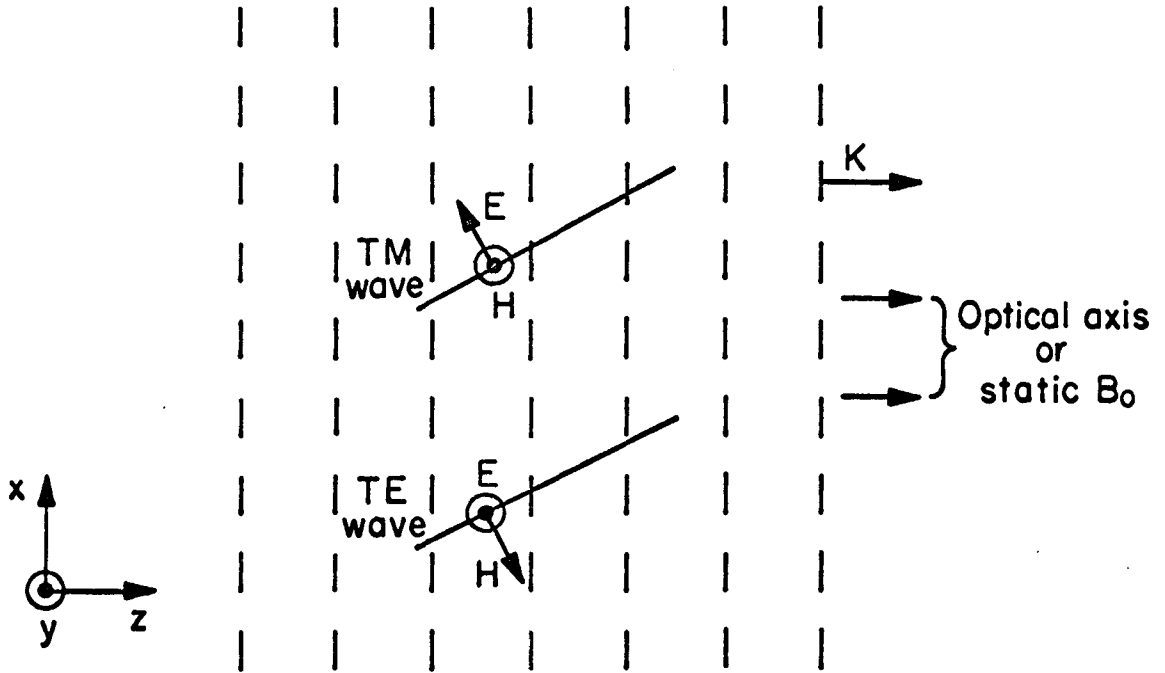

Fig. 19. TE and TM waves in uniaxial media

A. Wave in Infinite and Half-Space

1. TE wave (Fig. 19)

We find for the electric field wave equation

$$\nabla^2 E - \mu_0 \frac{\partial^2}{\partial t^2} (\epsilon' E) = 0 \quad (\text{for the dielectric})$$

$$\nabla^2 E - \mu_0 \epsilon_0 \frac{\partial^2 E}{\partial t^2} = 0 \quad (\text{for the plasma})$$

with  $\underline{E} = E \underline{e}_y$ . These equations are to be expected because, as  $\underline{E}$  is in a plane normal to the anisotropy axis, it does not see the anisotropy, and we get the same equation as for the isotropic medium. For the uniaxial plasma, as  $B_0$  is infinite, only the electric field z-component, if it exists, can interact with the plasma (see next section).

2. TM wave (Fig. 19)

Here

$$\underline{E} = E_x \underline{e}_x + E_z \underline{e}_z \quad \text{and} \quad \underline{H} = H_y \underline{e}_y$$

and the electric field sees the anisotropy of the medium. This leads to drastic changes relative to the isotropic case.

a. Uniaxial dielectric

Maxwell's equations are

$$\nabla \times \underline{E} = -\mu_0 \frac{\partial \underline{H}}{\partial t} \implies \frac{\partial E_x}{\partial z} - \frac{\partial E_z}{\partial x} = -\mu_0 \frac{\partial H}{\partial t} \quad (4A.1)$$

$$\nabla \times \underline{H} = \frac{\partial}{\partial t} (\underline{\epsilon} \cdot \underline{E}) \implies \begin{cases} -\frac{\partial H}{\partial z} = \frac{\partial}{\partial t} (\epsilon' E_x) \\ \frac{\partial H}{\partial x} = \frac{\partial}{\partial t} (\epsilon'' E_z) \end{cases} \quad (4A.2)$$

From Floquet's theorem and the superposition principle we can write

$$H = \sum_n H_n e^{i\delta x + i(\kappa+nK)z - i(\omega+n\Omega)t}$$

$$\underline{E} = \sum_n (E_{nx} \underline{e}_x + E_{nz} \underline{e}_z) e^{i(\kappa+nK)z + i\delta x - i(\omega+n\Omega)t}$$

Putting these expressions in 4A.1 and 4A.2, equating the components with the same frequency, and eliminating  $H_n$  and  $E_{nx}$  as we did in the isotropic dielectric problem, we get

$$\left[ \frac{D_n D'_n - G_n G'_n}{G'_n} + \frac{1}{G'_{n+1}} + \frac{1}{G'_{n-1}} \right] E_{nz} + \left[ \frac{D_n}{G'_n} + \frac{D'_{n+1}}{G'_{n+1}} \right] E_{n+1,z} +$$

$$\left[ \frac{D_n}{G'_n} + \frac{D'_{n-1}}{G'_{n-1}} \right] E_{n-1,z} + \frac{1}{G'_{n+1}} E_{n+2,z} + \frac{1}{G'_{n-1}} E_{n-2,z} = 0 \quad (4A.3)$$

where

$$D_n = \frac{2}{\epsilon_1} \left[ 1 - \frac{(\kappa+nK)^2}{\beta_n'^2} \right] \quad D'_n = \frac{2}{\epsilon_3} \left[ 1 - \left( \frac{\delta}{\beta_n'''} \right)^2 \right]$$

$$G_n = \frac{2}{\epsilon_1} \frac{\delta(\kappa+nK)}{\beta_n'^2} \quad G'_n = \frac{2}{\epsilon_3} \frac{\delta(\kappa+nK)}{\beta_n'''^2}$$

$$\beta_n'^2 = \mu_o \epsilon_o \epsilon_r' \omega_n^2 \quad \beta_n'''^2 = \mu_o \epsilon_o \epsilon_r''' \omega_n^2$$

or in a matrix form

$$\|M\| \cdot |E_z| = 0 \quad (4A.4)$$

which is similar to 2B.17 but with different elements, and

$$\text{Det } \|M\| = 0 \quad (4A.5)$$

is the dispersion equation.

From equation 4A.4 we can compute the relative amplitudes  $E_{nz}/E_{oz}$  and then from Maxwell's equations we get  $E_{nx}/E_{oz}$  and  $H_n/E_{oz}$ .

To get an idea about the wave vector diagram, let us take the limits  $\epsilon_1 \rightarrow 0$  and  $\epsilon_3 \rightarrow 0$ . At these limits, equation 4A.3 becomes

$$(\kappa+nK)^2 + \frac{\epsilon_r'}{\epsilon_r'''} \delta^2 = \frac{K^2}{R'^2} \left( \frac{\omega_n}{\Omega} \right)^2$$

or

$$(X+n)^2 + \frac{\epsilon_r'}{\epsilon_r'''} Y^2 = \left( \frac{\omega_n}{R'\Omega} \right)^2$$

where

$$X = \kappa/K \qquad Y = \delta/K$$

$$R' = \frac{c'}{v_d} = \frac{1}{v_d \sqrt{\mu_0 \epsilon_0 \epsilon_r'}}$$

This is a family of ellipses centered at  $X = -n$  with axes ratio  $(\epsilon_r' / \epsilon_r''')$ . The envelope of this family of ellipses is a straight line

$$Y = \left( \frac{\epsilon_r'''}{\epsilon_r'} \right)^{1/2} \frac{1}{\sqrt{R'^2 - 1}} \left( X - \frac{\omega}{\Omega} \right)$$

So the wave vector diagram for a uniaxial dielectric looks like the isotropic dielectric diagram (Fig. 3), with the circles replaced by ellipses.

The characteristic equation of the system 4A.3 is

$$\rho^4 + B\rho^3 + A\rho^2 + B\rho + 1 = 0$$

where

$$A = \frac{4}{\epsilon_1 \epsilon_3} [1 - R'^2] + 2$$

$$B = \frac{2}{\epsilon_1} (1 - R'^2) + \frac{2}{\epsilon_3}$$

$$R' = \frac{c'}{v_d}$$

$c'$  = speed of light in the  $x$  direction

From Poincare' convergence Theorem [18,21], the sonic region is found equal to

$$1 - \epsilon_1 \leq R'^2 \leq 1 + \epsilon_1 \qquad \text{for } R'^2 \leq 1 + \frac{\epsilon_1}{\epsilon_3} - 2\epsilon_1$$

$$0 \leq R'^2 \leq 1 + \epsilon_1 \quad \text{for } R'^2 > 1 + \frac{\epsilon_1}{\epsilon_3} - 2\epsilon_1$$

Remarking that

$$1 - 2\epsilon_1 + \frac{\epsilon_1}{\epsilon_3} = 1 - \epsilon_1 + \epsilon_1 \left( \frac{1}{\epsilon_3} - 1 \right) \geq 1 - \epsilon_1$$

then the sonic region is given by

$$1 - \epsilon_1 \leq R'^2 \leq 1 + \epsilon_1 \quad \text{for all } R'^2$$

and the value of  $\epsilon_3$  has no effect on the sonic region.

b. Uniaxial plasma

Maxwell, Newton and the continuity equations are

$$\nabla \times \underline{E} = -\mu_0 \frac{\partial \underline{H}}{\partial t} \quad (4A.6)$$

$$\nabla \times \underline{H} = \epsilon_0 \frac{\partial \underline{E}}{\partial t} + \underline{J} \quad (4A.7)$$

$$\nabla \cdot \underline{H} = 0$$

$$\nabla \cdot \underline{E} = \rho / \epsilon_0$$

$$\nabla \cdot \underline{J} + \frac{\partial \rho}{\partial t} = 0$$

$$m \frac{d\underline{v}}{dt} = q\underline{E} + q\underline{v} \times \underline{B}_0 \quad (4A.8)$$

$$\underline{J} = Nq\underline{v} \quad (4A.9)$$

and  $\underline{B}_0 = B_0 \underline{e}_z =$  static magnetic field.

From 4A.8 and 4A.9 we have



$$\frac{d}{dt} \left( \frac{\underline{J}}{N} \right) = \frac{q}{m} \underline{E} + \frac{\underline{J}}{N} \times \underline{\omega}_B \quad (4A.10)$$

where  $\underline{\omega}_B = \frac{q}{m} \underline{B}_0$ .

Let  $\underline{J}_T = \underline{J} \times \underline{e}_z$ , then  $|\underline{J} \times \underline{\omega}_B| = J_T \omega_B$ ; but, as the medium is uniaxial ( $B_0 \rightarrow \infty$ ), then we must have  $J_T \approx 0$  and

$$\underline{J} = J_z \underline{e}_z$$

Taking  $\underline{E} = \frac{\partial \underline{A}}{\partial t}$ , equation 4A.10 reduces to

$$\underline{J} = \epsilon_0 \omega_p^2(z,t) A_z \underline{e}_z$$

and equations 4A.6 and 4A.7 become

$$\nabla \times \underline{A} = -\mu_0 \underline{H} \quad (4A.11)$$

$$\nabla \times \underline{H} = \epsilon_0 \frac{\partial^2 \underline{A}}{\partial t^2} + \epsilon_0 \omega_p^2 A_z \underline{e}_z \quad (4A.12)$$

Using Floquet's theorem we can write

$$\underline{H} = \underline{e}_y \sum_n H_n e^{i(\kappa+nK)z + i\delta x - i\omega_n t}$$

$$\underline{A} = \sum_n (A_{nx} \underline{e}_x + A_{nz} \underline{e}_z) e^{i(\kappa+nK)z + i\delta x - i\omega_n t}$$

with  $E_{nx/z} = -i\omega_n A_{nx/z}$ . Putting these expressions in 4A.11 and 4A.12, then equating the elements with the same frequency, we find

$$-\delta A_{nz} + (\kappa+nK) A_{nx} = i\mu_0 H_n$$

$$-(\kappa+nK) H_n = i\epsilon_0 \omega_n^2 A_{nx}$$

$$\delta H_n = i\epsilon_o \omega_n^2 A_{nz} - i\epsilon_o \omega_{po}^2 [A_{nz} + \frac{N_1}{2} A_{n+1,z} + \frac{N_1}{2} A_{n-1,z}]$$

Solving this system we get

$$A_{nx} = -\frac{\delta(\kappa+nK)}{\beta_n^2 - (\kappa+nK)^2} A_{nz}$$

$$H_n = \frac{i\epsilon_o \delta \omega_n^2}{\beta_n^2 - (\kappa+nK)^2} A_{nz}$$

$$D_n A_{nz} + A_{n+1,z} + A_{n-1,z} = 0$$

where

$$D_n = \frac{2}{N_1} \left[ 1 - \frac{\beta_n^2}{\beta_{po}^2} \left( 1 - \frac{\delta^2}{\beta_n^2 - (\kappa+nK)^2} \right) \right] \quad (4A.13)$$

or in a matrix form

$$||M|| \cdot |A_z| = 0 \quad (4A.14)$$

and

$$\Delta(\delta, \kappa, \omega) = \text{Det } ||M|| = 0 \quad (4A.15)$$

is the dispersion equation.

In the limit  $N_1 \rightarrow 0$  the dispersion equation reduces to (from 4A.13)

$$\delta^2 + \left( 1 - \frac{\omega_{po}^2}{\omega_n^2} \right) (\kappa+nK)^2 = \beta_n^2 - \beta_{po}^2$$

or

$$Y^2 + \left( 1 - \frac{\omega_{po}^2}{\omega_n^2} \right) (X+n)^2 = \frac{\omega_n^2 - \omega_{po}^2}{R^2 \Omega^2} \quad (4A.16)$$

where

$$Y = \frac{\delta}{K} , \quad X = \frac{\kappa}{K} , \quad \omega_{po}^2 = \frac{q^2 N_o}{m \epsilon_o} , \quad R = \frac{c}{v_d}$$

This is a family of conics, and the wave vector diagram will consist of

-- hyperbolas for  $n$  such that  $\omega + n\Omega < \omega_{po}$

-- ellipses for  $n$  such that  $\omega + n\Omega > \omega_{po}$

All the special and interesting properties encountered in a uniaxial plasma are studied in the following three cases:

Case (1):  $N_1 = 0.25$  ,  $\Omega = 0$  ,  $\omega = \frac{4}{3} \omega_{po} > \omega_{po}$

The wave vector diagram shown in Fig. 20 is a family of ellipses which interact strongly near their intersection points and lead to the apparition of stop-bands. As the group propagation angle is given by  $\theta_y = -\text{arc cotg } \frac{d\delta}{d\kappa}$  , then there is propagation for all values of  $\theta$  , which is to be expected because  $\omega > \omega_{po}$ .

Case (2):  $N_1 = 0.25$  ,  $\Omega = 0$  ,  $\omega = 0.8 \omega_{po} < \omega_{po}$

For this case we get the diagram of Fig. 21 which consists of a family of hyperbolas with stop-bands near the interaction points. For the limit  $N_1 \rightarrow 0$  we know that there is group propagation only inside a cone with half angle  $c = \text{arc sin } \frac{\omega}{\omega_{po}}$  . In fact, we see on Fig. 21 that, at this limit, the slope of the curves is

$$|\text{asymptote slope}| = \sqrt{\frac{\omega^2}{\omega_{po}^2} - 1} \leq |\text{slope}| < \infty$$

But for  $N_1 \neq 0$  the slope near the stop-bands goes to zero, and this

allows propagation for all angles  $\theta$ . This is a special effect due to the presence of the disturbance and it will be explained physically in a later section.

Case (3):  $N_1 = 0.25$ ,  $R = 3.5$ ,  $\omega = 2.5\Omega$ ,  $\omega = \frac{4}{3}\omega_{po}$

Here there are harmonics at frequencies  $\omega + n\Omega$ , and the plasma frequency  $\omega_{po}$  will be in the middle of the spectrum. Therefore, we expect to have a mixed wave vector diagram which contains ellipses and hyperbolas. Also, there is the disturbance motion effect. In Fig. 22 we plotted the corresponding wave vector diagram, and we remark the following factors:

- The modes ( $q \geq 0$ ) are ellipses because  $\omega + q\Omega > \omega_{po}$
- The modes ( $q < 0$ ) are hyperbolas because  $\omega + q\Omega < \omega_{po}$
- Because of the disturbance motion, the ellipses are not equal and the hyperbolas' asymptotic slopes are not the same.

In this case too, all the modes propagate for all  $\theta$ , even the modes which, in the limit  $N_1 \rightarrow 0$ , were limited to a certain cone of propagation.

Finally, the relative amplitudes of the harmonics can be computed from equation 4A.14, and from Poincare convergence theorem we find that there is no sonic region. For the reflection coefficients from a half-space, we can use the results of Section II.C with  $D_{nq}$  given by equation 4A.13.

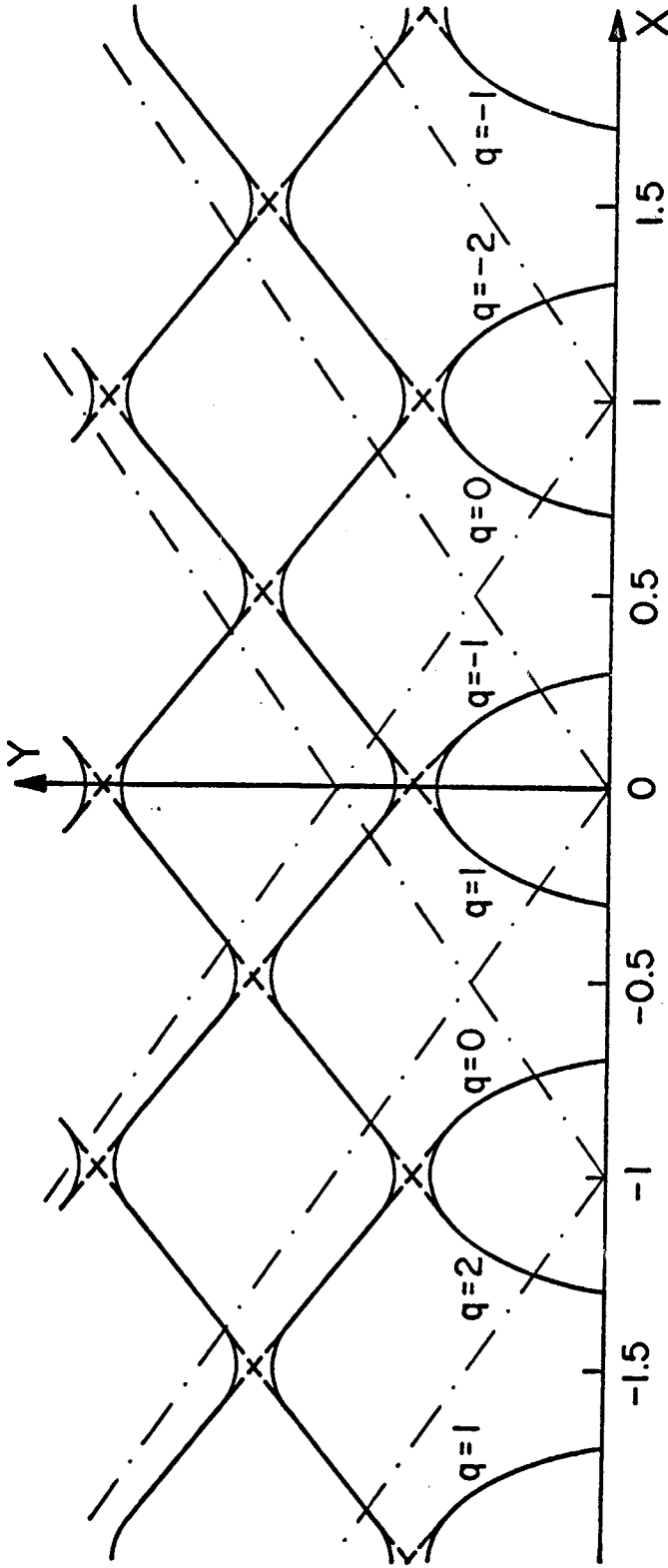

Fig. 21. Wave vector diagram for a uniaxial plasma:  $v_d = 0$ ,  $\omega_{p0}/\omega = 1.25$ ,  $N_1 = 0.25$ ,  $\lambda/\Lambda = 1.4$ . The dashed line corresponds to  $N_1 \rightarrow 0$ .

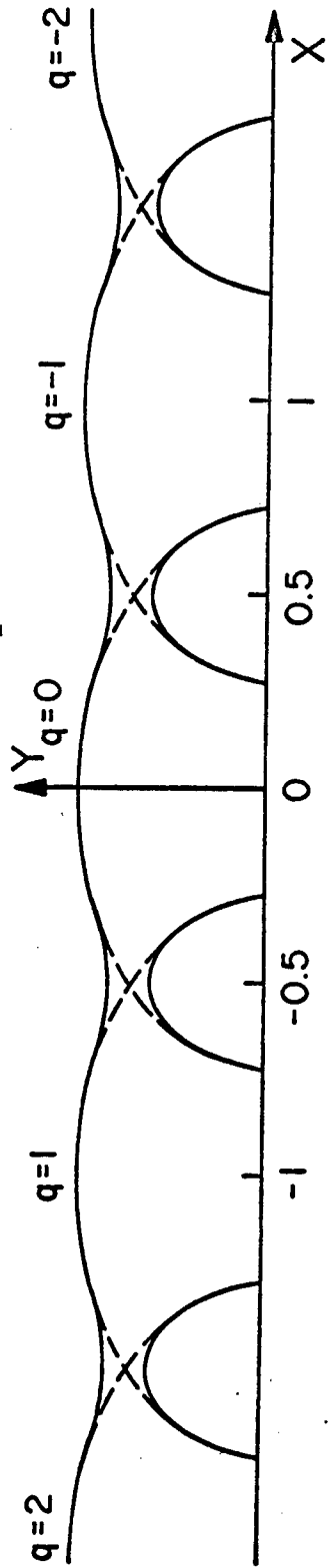

Fig. 20. Wave vector diagram for a uniaxial plasma:  $v_d = 0$ ,  $\omega_{p0}/\omega = 0.75$ ,  $N_1 = 1.4$ ,  $\lambda/\Lambda = 1.4$ . The dashed line corresponds to  $N_1 \rightarrow 0$ .

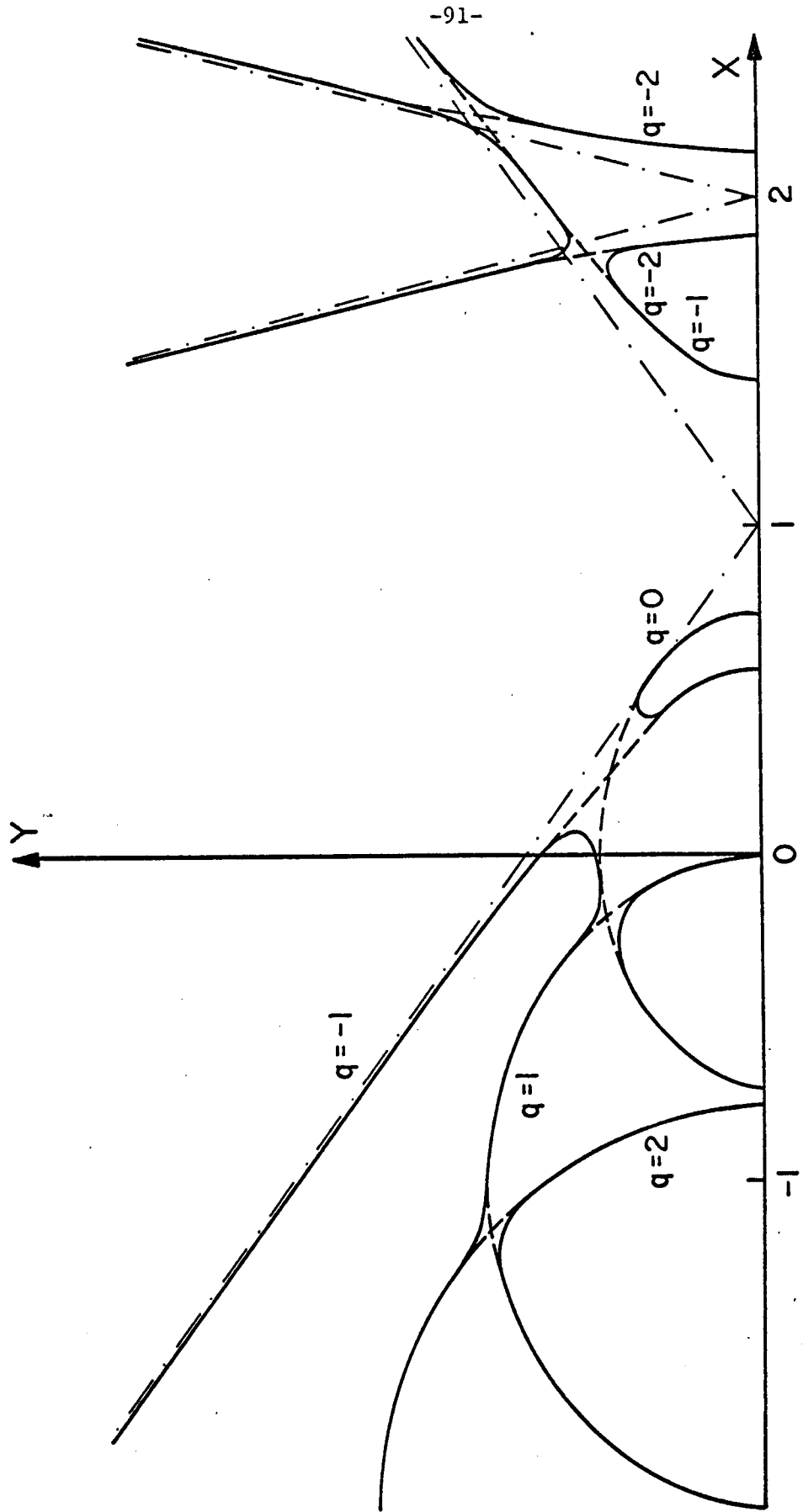

Fig. 22. Wave vector diagram for a uniaxial plasma:  $R = 3.5$ ,  $\omega/\Omega = 2.5$ ,  $\omega/\omega_{p0} = 0.75$ ,  $N_1 = 0.25$   
 The dashed line corresponds to  $N_1 \rightarrow 0$

## B. Dipole Radiation

The dipole moment, the optical axis (or  $\underline{B}_0$  for the uniaxial medium), and the disturbance propagation vector are supposed to be parallel to the z-axis.

For a magnetic dipole, the electric field is in a plane normal to the z-direction, and it does not see the anisotropy as we showed for the TE wave, thus:

- In a uniaxial dielectric the radiation pattern is identical to the pattern in an isotropic dielectric with  $\epsilon = \epsilon'(z,t)$ .
- In a uniaxial plasma, the radiation pattern is identical to the pattern in vacuum (i.e.,  $\epsilon = \epsilon_0$ ); therefore, only the electric dipole is studied in detail.

### 1. Electric dipole in a uniaxial dielectric

The wave-vector diagram for a uniaxial dielectric is the same as the isotropic dielectric diagram (Fig. 3) with the circles replaced by ellipses, because  $\epsilon'_r \neq \epsilon'''_r$ ; therefore, all the results found in Section IIF.2 are valid here if we use the corresponding  $D_{nq}$  and diagram.

### 2. Electric dipole in a uniaxial plasma

The wave vector diagram is given in Fig. 22, and the field expression and radiation pattern are found in the same way as for the isotropic plasma. We get caustics, but also there are the cones of radiation on which surface the field is very large (see Appendix D). The cones of radiation appear only for some modes (with  $q$  such that  $\omega + q\Omega < \omega_{po}$ ), but because of the inhomogeneity created by the

disturbance, the radiation is not limited any more to the inside of the cone.

Let us consider two phase rays, 1 and 2, inside the phase cone angle (Fig. 23); then if at a point A we take the vector sum of the rays 2 and 1' (which is the reflected part of 1 from an inhomogeneity surface), we find the resulting ray outside the phase cone, in the previously forbidden region.

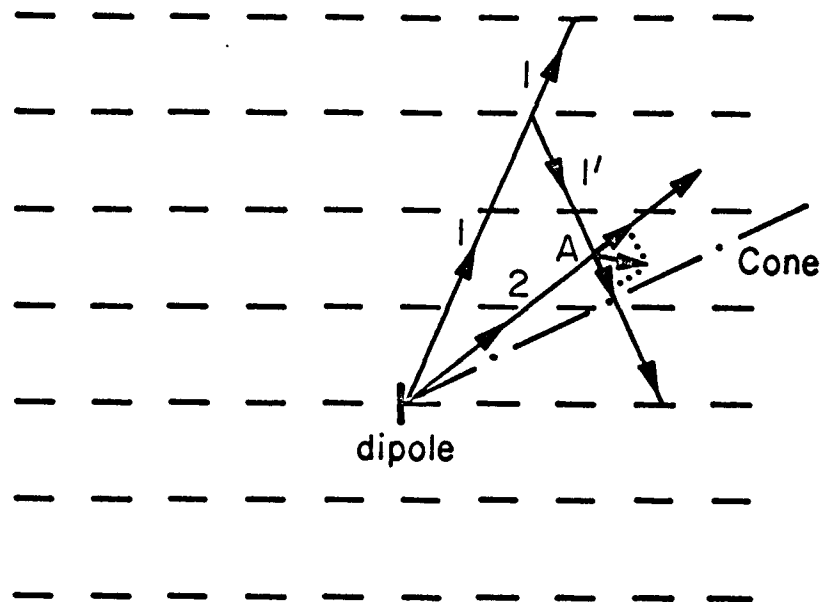

Fig. 23. Radiation in the cut-off cone



This was verified by computing and plotting the radiation pattern for a case where we expect to have cones.

In Figs. 24 and 25 we plotted  $\theta = f\left(\frac{\kappa s}{K}\right)$  and the radiation pattern of an electric dipole in a uniaxial plasma with stationary disturbance (i.e.,  $N(z) = N_0(1 + N_1 \cos Kz)$ ) and  $\omega > \omega_{p0}$ . No major difference with the isotropic case occurs.

In Figs. 26, 27, 28, 29 we plotted  $\theta = f\left(\frac{\kappa s}{K}\right)$  and the patterns for the harmonics ( $\omega, \omega+\Omega, \omega-\Omega$ ) of an electric dipole in a perturbed uniaxial plasma with

$$R = \frac{c}{v_d} = 3.5, \quad \omega/\Omega = 2.5, \quad \omega = \frac{4}{3} \omega_{p0}, \quad N_1 = 0.25$$

The harmonic ( $\omega-\Omega$ ) pattern contains caustics and cones because the mode  $q = -1$  in Fig. 22 has a hyperbolic wave vector diagram (i.e.,  $\omega-\Omega < \omega_{p0}$ ). The disturbance motion has an effect only on the caustic angles, but not on the cone angle (the cone angles are  $53^\circ$  and  $127^\circ = 180^\circ - 53^\circ$ ).

The fundamental ( $\omega$ ) pattern contains caustics but no clear cones. But for  $36^\circ < \theta < 53^\circ$  there is a slight increase in the field due to the up-conversion from the mode  $q = -1$  which has a cone (i.e., large field) in that region.

1000-100

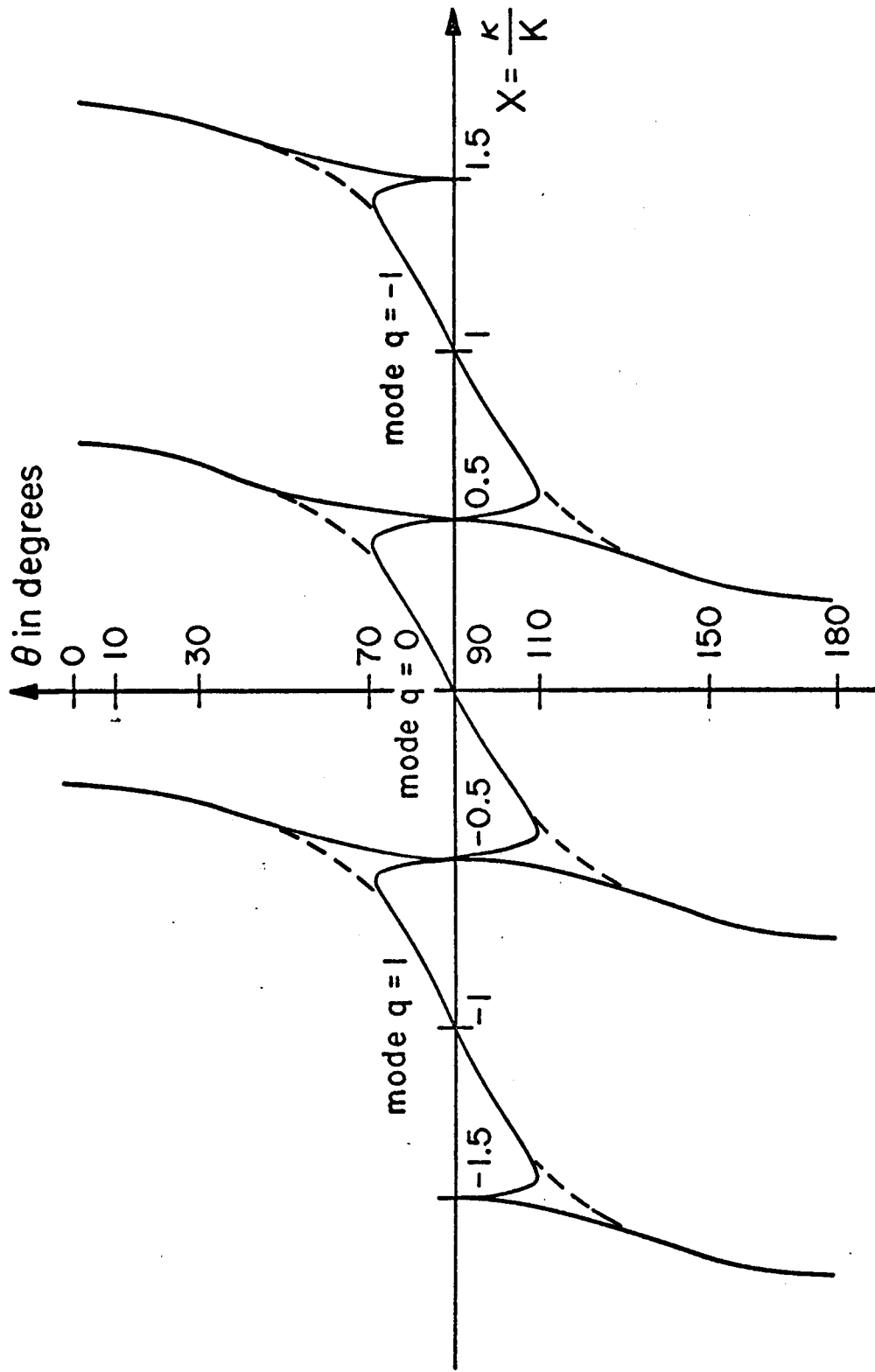

Fig. 24. Curve  $\theta = f(\kappa_s/K)$  for a uniaxial plasma:  $R = \infty$ ,  $v_d = 0$ ,  $\Omega = 0$ ,  $\omega_p/\omega = 0.75$ ,  $N_1 = 0.25$ .  
The dashed line corresponds to  $N_1 \rightarrow 0$ .

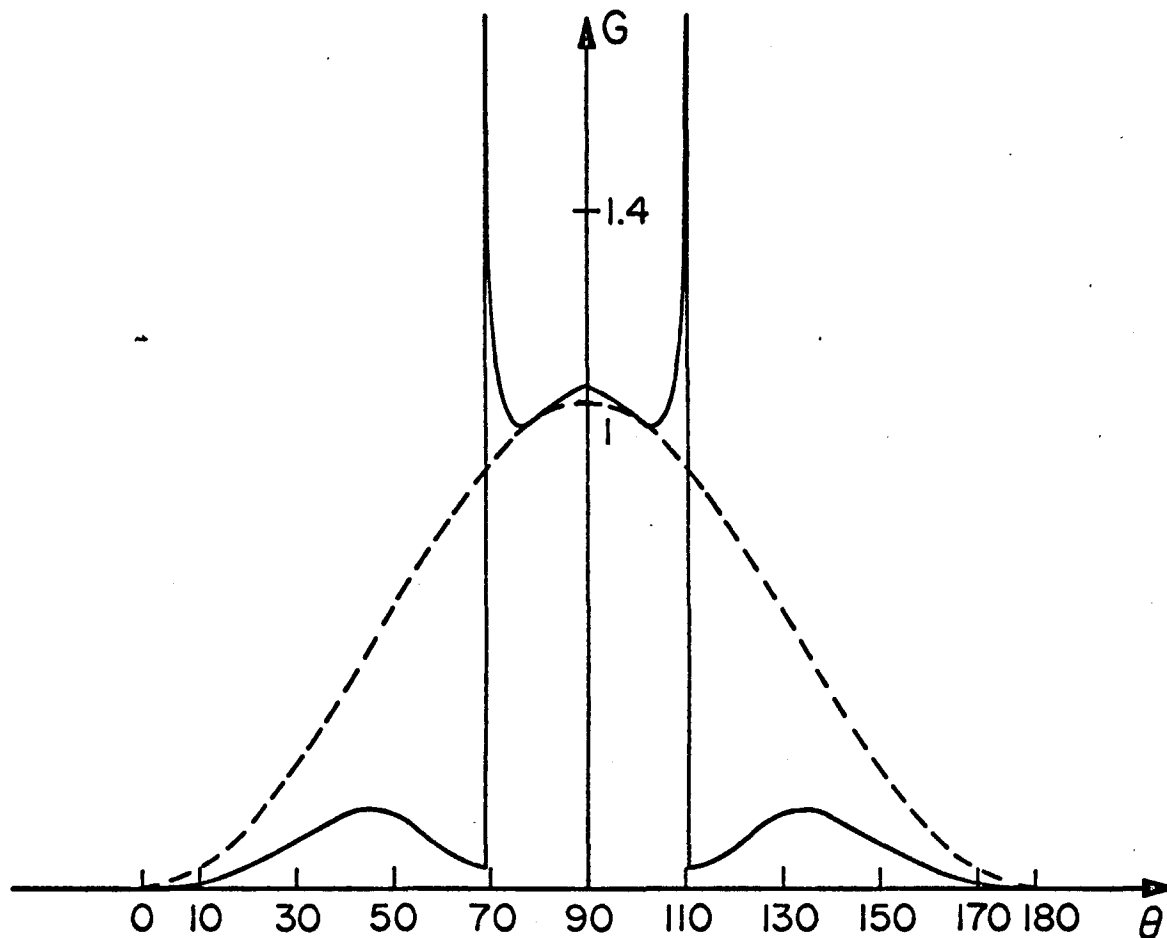
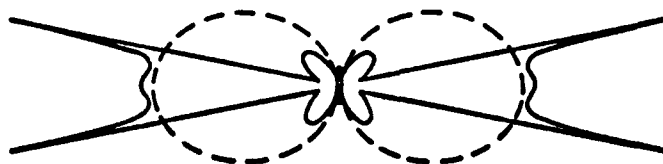

Fig. 25. Radiation pattern in a disturbed uniaxial plasma  $R = \infty$ ,  $v_d = 0$ ,  $\Omega = 0$ ,  $\omega_p/\omega = 0.75$ ,  $N_1 = 0.25$ . The dashed line corresponds to the pattern in vacuum.

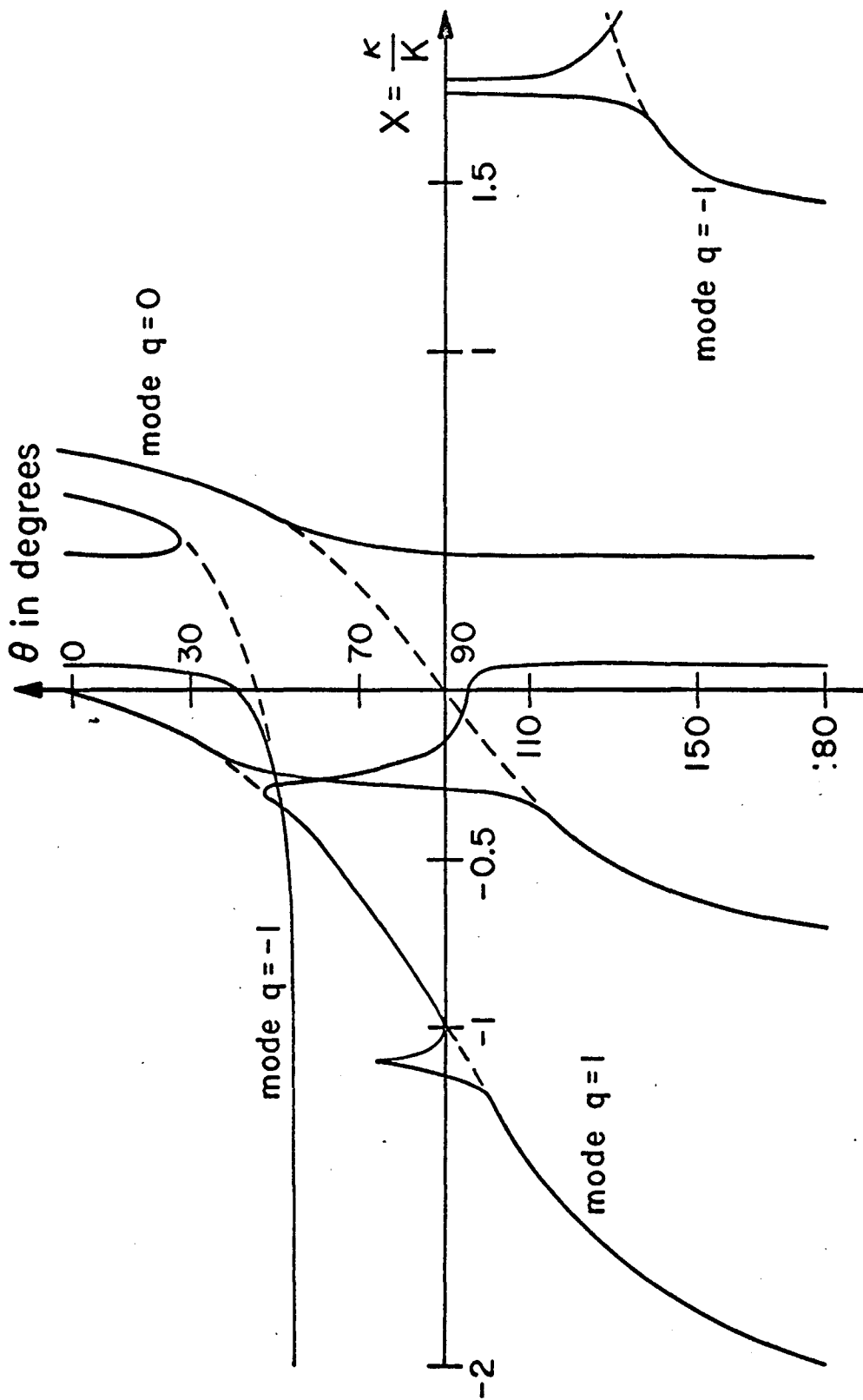

Fig. 26. Curve  $\theta = f(\kappa_s/K)$  for a uniaxial plasma:  $R = 3.5$ ,  $\omega/\Omega = 2.5$ ,  $\omega_p/\omega = 0.75$ ,  $N_1 = 0.25$ . The dashed line corresponds to  $N_1 \rightarrow 0$ .

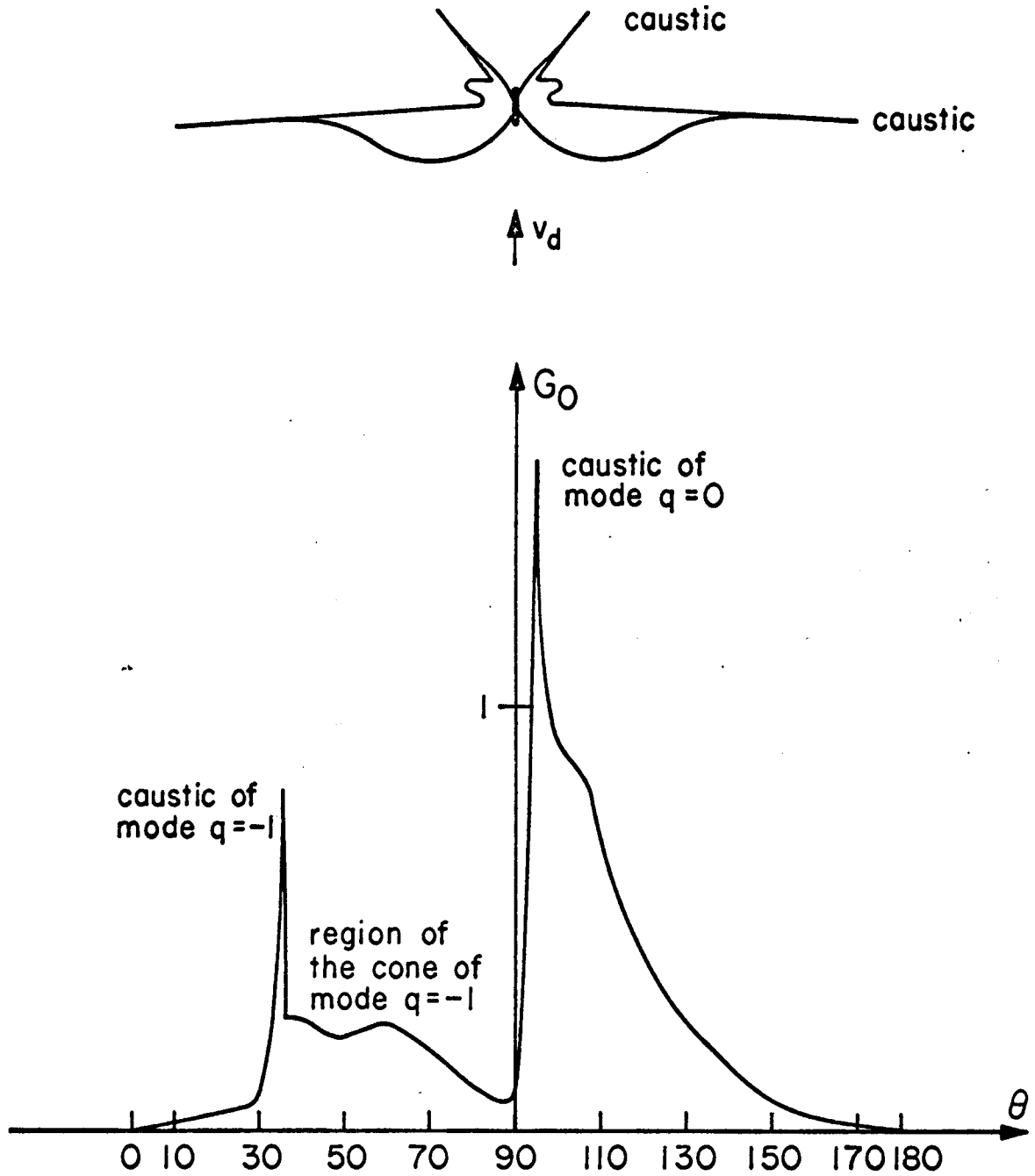

Fig. 27. Fundamental radiation pattern of a dipole in a disturbed uniaxial plasma:  $R = 3.5$ ,  $\omega/\Omega = 2.5$ ,  $\omega_p/\omega = 0.75$ ,  $N_1 = 0.25$

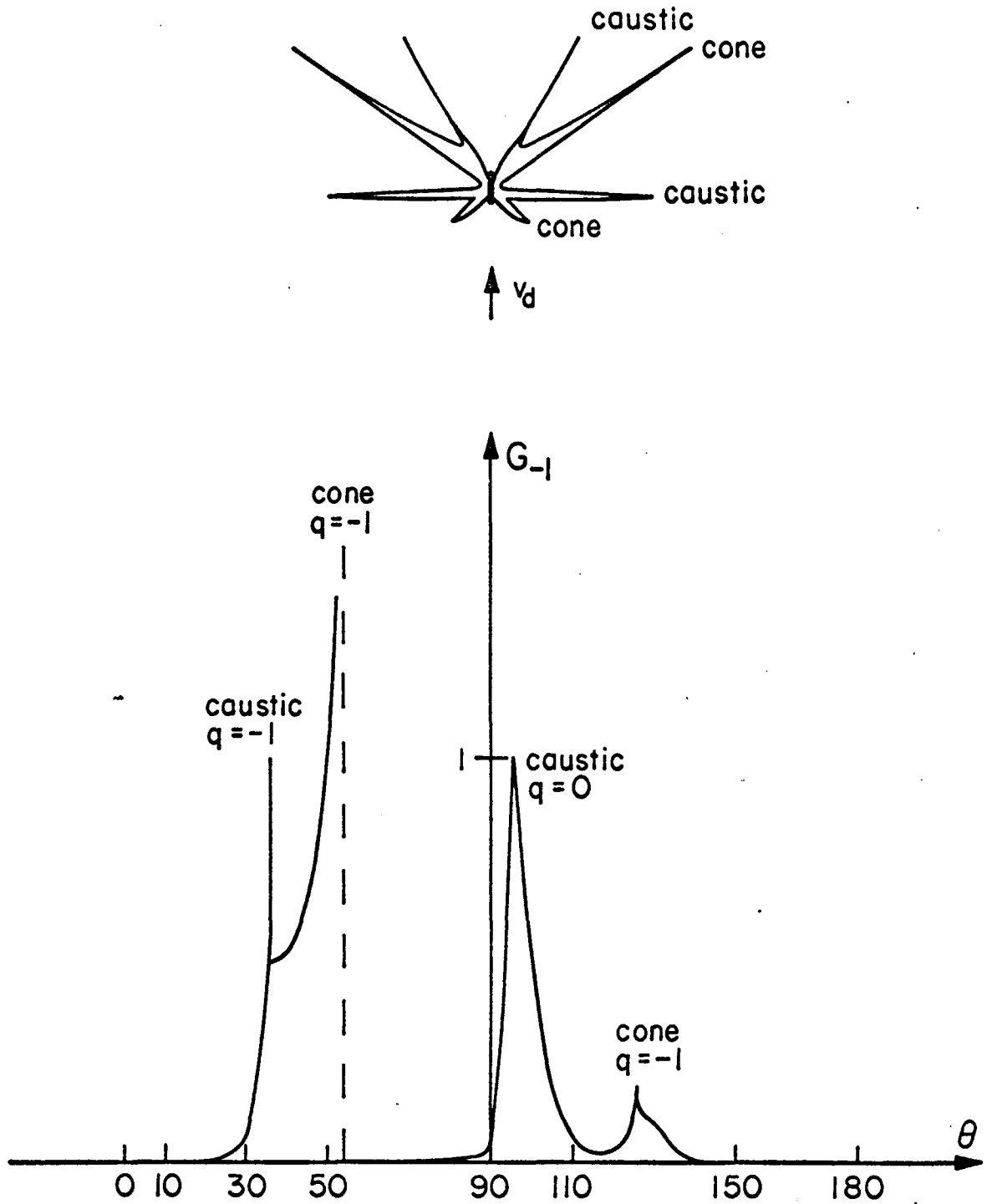

Fig. 28. Harmonic  $(\omega - \Omega)$  radiation pattern in a disturbed uniaxial plasma:  $R = 3.5$ ,  $\omega/\Omega = 2.5$ ,  $\omega_{po}/\omega = 0.75$ ,  $N_1 = 0.25$

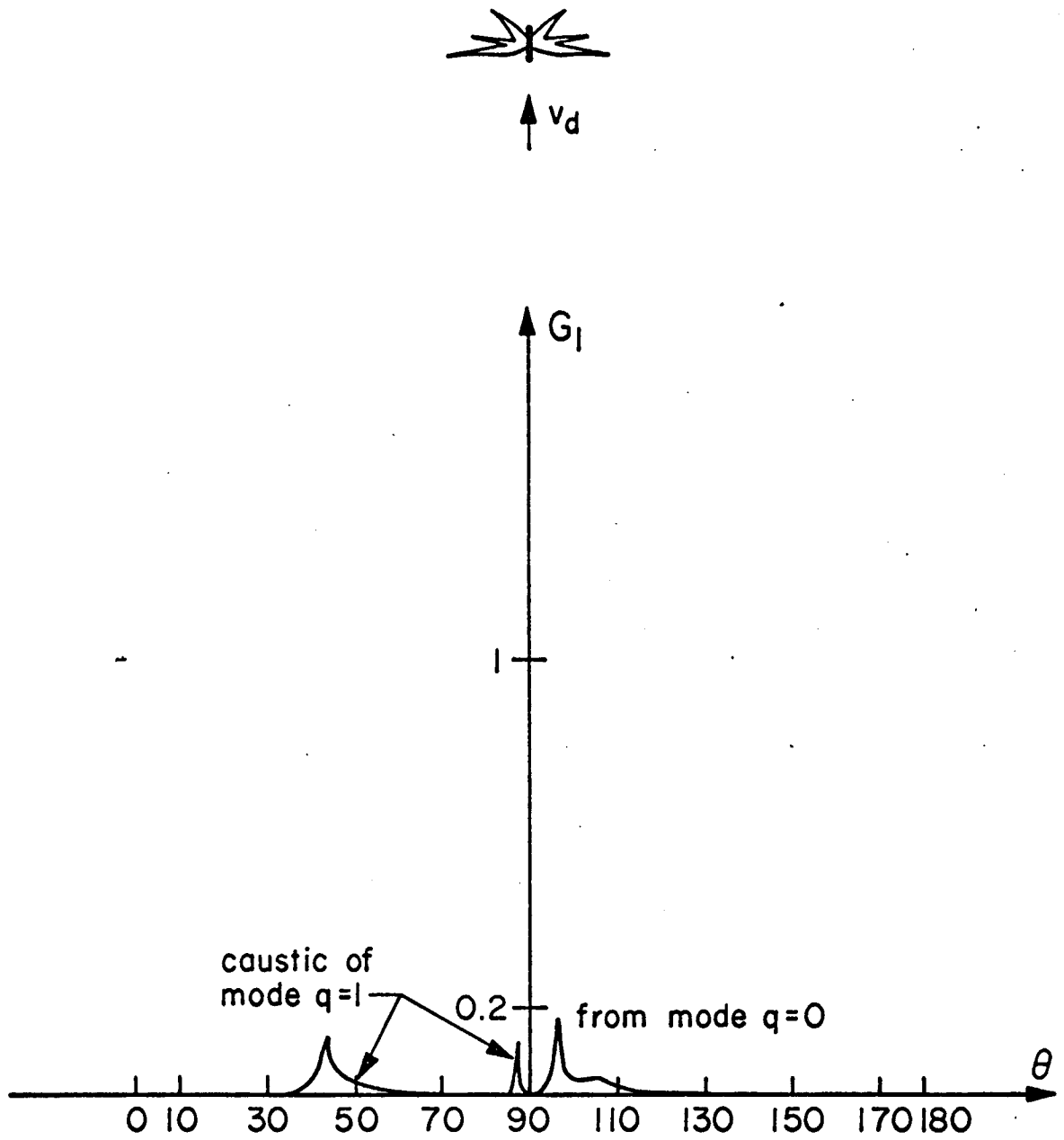

Fig. 29: Harmonic  $(\omega + \Omega)$  radiation pattern in a disturbed uniaxial plasma:  $R = 3.5$ ,  $\omega/\Omega = 2.5$ ,  $\omega_{p0}/\omega = 0.75$ ,  $N_1 = 0.25$

## V. CERENKOV RADIATION IN SPACE-TIME PERIODIC MEDIA

In this chapter we study the radiation from a moving electric charge, with constant velocity, in sinusoidally space-time periodic media. In a dielectric (Sections A and B), we get transition radiation and, under some conditions, Cerenkov radiation. In a plasma (Section C), there is only transition radiation. The charge is assumed to move parallel to the disturbance wave vector (i.e., z-direction).

### A. Fields

The current density due to the charged particle in cylindrical coordinates is

$$\underline{I} = \underline{e}_z \frac{ev_p}{2\pi\rho} \delta(\rho) \delta(z - v_p t)$$

where

$e$  = charge of the particle

$v_p$  = velocity of the particle

The radiated electromagnetic field is transverse magnetic relative to the z-axis, and most of the basic results found in the study of the electric dipole are valid here. Two factors must be taken into account

- the current expression is different
- the radiated wave spectrum is continuous not discrete, and we have to integrate over all the frequencies.

#### 1. Field expression

The magnetic field can be written



$$H = \sum_n \sum_q \int_{-\infty}^{\infty} \int_{-\infty}^{\infty} W_q(\kappa, \omega) H_{nq} H_1^{(1)}(\delta_q \rho) e^{i(\kappa+nK)z - i(\omega+n\Omega)t} d\kappa d\omega \quad (5A.1)$$

with  $\underline{H} = H e_{-\phi}$ , and the source condition is

$$2\pi\rho H \Big|_{\rho \rightarrow 0} = e v_p \delta(z - v_p t) \quad (5A.2)$$

Putting the expression of H in 5A.2, we get

$$\begin{aligned} \sum_n \sum_q \int_{-\infty}^{\infty} \int_{-\infty}^{\infty} \frac{A'_{nq} W_q}{\delta_q} E_{oqz} e^{i(\kappa+nK)z - i(\omega+n\Omega)t} d\kappa d\omega \\ = \frac{iev_p}{4} \delta(z - v_p t) \end{aligned}$$

or

$$\int_{-\infty}^{+\infty} \left[ \int_{-\infty}^{+\infty} \sum_n e^{-in\Omega t} \int_q \alpha_q A'_{nq} e^{i(\kappa+nK)z} d\kappa - \frac{ie}{4} e^{i\omega \frac{z}{v_p}} \right] e^{-i\omega t} d\omega = 0$$

where

$$\begin{aligned} A'_{nq} &= \frac{H_{nq}}{E_{oqz}} \quad (\text{determined in Section II.F.2}) \\ \alpha_q &= \frac{W_q E_{oqz}}{\delta_q} \end{aligned}$$

and we used the relations

$$\begin{aligned} \delta(ax) &= \frac{1}{a} \delta(x) \\ \delta(x) &= \int_{-\infty}^{\infty} e^{i\omega x} d\omega \end{aligned}$$

This equation must be satisfied for all t, therefore

$$\sum_n \sum_q \int_{-\infty}^{\infty} \alpha_q A'_{nq} e^{i(\kappa+nK)z - in\Omega t} d\kappa = \frac{ie}{4} e^{i(\omega/v_p)z}$$

and to have this relation too satisfied for all  $z$  and  $t$ , we must have

$$\kappa = \omega/v_p \quad (5A.3)$$

$$\sum_q \alpha_q A'_{nq} = 0 \quad \text{for } n \neq 0 \quad (5A.4)$$

$$\sum_q \alpha_q A'_{0q} = \frac{ie}{4} \quad (5A.5)$$

or in a matrix form

$$||A'|| \cdot |\alpha| = |P| \quad (5A.6)$$

where

$$|P| = \text{column vector with elements } \begin{cases} P_n = 0 & \text{for } n \neq 0 \\ P_0 = ie/4 \end{cases}$$

As  $\kappa$  is related to  $\omega$ , then the integration over  $\kappa$  can be deleted, and the  $H$  field is completely determined by

$$H = \sum_n \sum_q \int_{-\infty}^{\infty} \alpha_q(\omega) \delta_q(\omega) A'_{nq}(\omega) H_1^{(1)}(\delta_q \rho) \times e^{i(\frac{\omega}{v_p} + nK)z - i(\omega + n\Omega)t} d\omega \quad (5A.7)$$

and in the far field.

$$H = \sqrt{\frac{2}{\pi\rho}} e^{-i\frac{3\pi}{4}} \sum_n \sum_q \int_{-\infty}^{\infty} \alpha_q A'_{nq} \delta_q^{1/2} e^{i\chi r} d\omega \quad (5A.8)$$

where

$$\chi = \delta_q \sin \theta + (\frac{\omega}{v_p} + nK) \cos \theta - (\omega + n\Omega) \frac{t}{r} \quad (5A.9)$$

$$\rho = r \sin \theta$$

From the above expressions we see that a band of the spectrum near the frequency  $\omega + n\Omega$  will propagate with a phase angle

$$\theta_{p,nq} = \text{arctg} \frac{\delta_q}{\kappa + nK} = \text{arctg} \frac{\delta_q}{\frac{\omega}{v_p} + nK} \quad (5A.10)$$

The integral in 5A.8 can be computed by the steepest descent method.

For  $r \rightarrow \infty$  with  $t/r$  staying finite, we get (see Appendix C)

$$H = \frac{-2i}{r \sin \theta} \sum_n \sum_q \alpha_{qs} A'_{nq,s} \sqrt{\frac{\delta_{qs}}{|\delta''_{qs}|}} e^{i\chi_s r + i \frac{\pi}{4}(1 - \text{sign } \delta''_{qs})}$$

where the index  $s$  means the value at  $\omega = \omega_s =$  saddle point, and  $\omega_s$  is given by

$$\left. \frac{d\chi}{d\omega} \right|_{\omega=\omega_s} = 0 \quad (5A.11)$$

or

$$\sin \theta \left. \frac{d\delta_q}{d\omega} \right|_{\omega=\omega_s} + \frac{\cos \theta}{v_p} - \frac{t}{r} = 0 \quad (5A.12)$$

## 2. Radiation cones

From equation 5A.12 we have

$$r \cos \theta + v_p \delta'_q(\omega_s) r \sin \theta = v_p t$$

or

$$z + v_p \delta'_q(\omega_s) \rho = v_p t \quad (\text{see Fig. 30})$$

This is the equation of a cone with axis  $z$ , vertex at  $v_p t$  (which is the position of the particle) and half angle  $\phi_{qs}$  given by

$$\operatorname{tg} \phi_{qs} = \frac{1}{v_p \delta'_q(\omega_s)}$$

Hence, for a given mode of radiation, the band of the spectrum around  $\omega_s$  (and  $\omega_s + n\Omega$ ) will be concentrated in space on the surface of a cone attached to the particle.

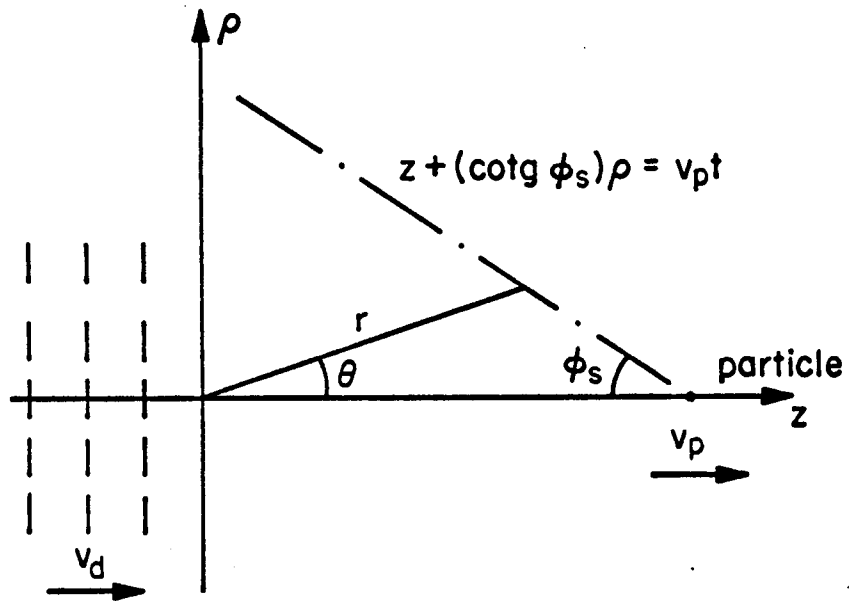

Fig. 30. Cerenkov and transition radiation geometry

### 3. Brillouin diagram

From Section II.F.2, where we studied the electric dipole radiation, we have (the subscript  $q$  is omitted for clarity of notation)

$$D_n E_{n\rho} + E_{n+1,\rho} + E_{n-1,\rho} + G_n E_{nz} = 0$$

$$D'_n E_{nz} + E_{n+1,z} + E_{n-1,z} + G_n E_{n\rho} = 0$$

where

$$D_n = \frac{2}{\epsilon_1} \left[ 1 - \left( \frac{\kappa+nK}{\beta_n} \right)^2 \right]$$

$$D'_n = \frac{2}{\epsilon_1} \left[ 1 - \left( \frac{\delta}{\beta_n} \right)^2 \right]$$

$$G_n = \frac{2}{\epsilon_1} \frac{\delta(\kappa+nK)}{\beta_n^2}$$

or in a matrix form

$$||D|| \cdot |E_\rho| + ||G|| \cdot |E_z| = 0$$

$$||D'|| \cdot |E_z| + ||G|| \cdot |E_\rho| = 0$$

where

$$||G|| = \text{diagonal matrix with elements } G_n$$

$$||D|| \text{ or } ||D'|| = \text{tridiagonal matrix with diagonal elements } D_n \text{ (or } D'_n) \text{ and off-diagonal elements equal to 1}$$

Solving this system for  $|E_z|$  we get

$$( ||G|| - ||D|| \cdot ||G||^{-1} \cdot ||D'|| ) \cdot |E_z| = 0$$

and the dispersion equation is given by

$$\text{Det}(\|G\| - \|D\| \cdot \|G\|^{-1} \cdot \|D'\|) = 0$$

At the limit  $\epsilon_1 \rightarrow 0$  the dispersion equation becomes

$$D_n D'_n = G_n^2$$

or

$$\delta^2 + (\kappa + nK)^2 = \beta_n^2 \quad (5A.14)$$

As  $\kappa = \omega/v_p$ , then

$$\delta^2 = \left(\frac{\omega + nKv_d}{v_c}\right)^2 - \left(\frac{\omega + nKv_p}{v_p}\right)^2 \quad (5A.15)$$

or

$$Y^2 - \frac{v_p^2 - v_c^2}{v_c^2} X^2 = n^2 \frac{(v_d - v_p)^2}{v_c^2 - v_p^2} \quad (5A.16)$$

where

$$X = X + n \frac{v_c^2 - v_p v_d}{v_c^2 - v_p^2}$$

$$Y = \delta/K, \quad X = \omega/Kv_p$$

$v_c$  = e.m. wave velocity

$v_d$  = disturbance velocity

$v_p$  = particle velocity

B. Radiation and Spectrum

In this section we study the angular distribution and the spectrum of the radiated field using the Brillouin diagram, for different relative values of  $v_c$ ,  $v_p$  and  $v_d$ .

1. Stationary disturbance ( $v_d = 0$ )

We assume a sinusoidally stratified media with

$$\epsilon = \epsilon_0 \epsilon_r (1 + \epsilon_1 \cos Kz)$$

then the limit dispersion equation 5A.16 becomes

$$Y^2 - \frac{v_p^2 - v_c^2}{v_c^2} X^2 = n^2 \frac{v_p^2}{v_c^2 - v_p^2}$$

with

$$x = X + n \frac{v_c^2}{v_c^2 - v_p^2}$$

In Fig. 31 we give the Brillouin diagram corresponding to different values of  $v_p/v_c$  and  $\epsilon_1 \rightarrow 0$ . For  $v_p/v_c < 1$ , the diagram consists of a family of ellipses (only 2 ellipses are shown), and only the modes  $q < 0$  appear. For  $v_p/v_c > 1$  the diagram consists of a family of hyperbolas (for  $q \neq 0$ ) with asymptotes parallel to the fundamental mode branch ( $q = 0$ ), which is a straight line.

For  $\epsilon_1 \neq 0$  strong interactions occur near the intersection points (Fig. 32).

In Fig. 33 we plotted the radiation angle

$$\phi = \text{arctg} \left( \frac{1}{v_p \delta' q} \right)$$

function of  $X = \omega/Kv_p$ , and in Fig. 34 we give the Brillouin diagrams and the radiation angle curves for specific modes.

In Fig. 34a  $v_p/v_c < 1$  and  $q = -1$ . The spectrum is limited to

$$\frac{1}{1 + \frac{v_p}{v_c}} < X < \frac{1}{1 - \frac{v_p}{v_c}}$$

or

$$\frac{Kv_p v_c}{v_p + v_c} < \omega < \frac{Kv_p v_c}{v_c - v_p}$$

and there is radiation in all directions. This is a transition type radiation and it is caused by the inhomogeneity of the medium.

In Fig. 34b  $v_p/v_c > 1$  and  $q = 0$ . Most of the radiation is concentrated on the Cerenkov cone surface, with cone angle

$$\phi_c = \arcsin \frac{v_c}{v_p}$$

but some parts of the spectrum are radiated inside the cone.

In Fig. 34c  $v_p/v_c > 1$  and  $q = -1$ . The radiation spectrum is

$$\omega \geq \frac{Kv_p v_c}{v_p + v_c}$$

The lower frequencies are radiated backward (i.e.,  $\phi = 0$ ) and the high frequencies are radiated in the Cerenkov cone.

In all the diagrams an inflection point leads to a caustic in the radiation pattern.

The above results, which are obtained by an elegant use of the Brillouin diagram without involved computations, match perfectly with



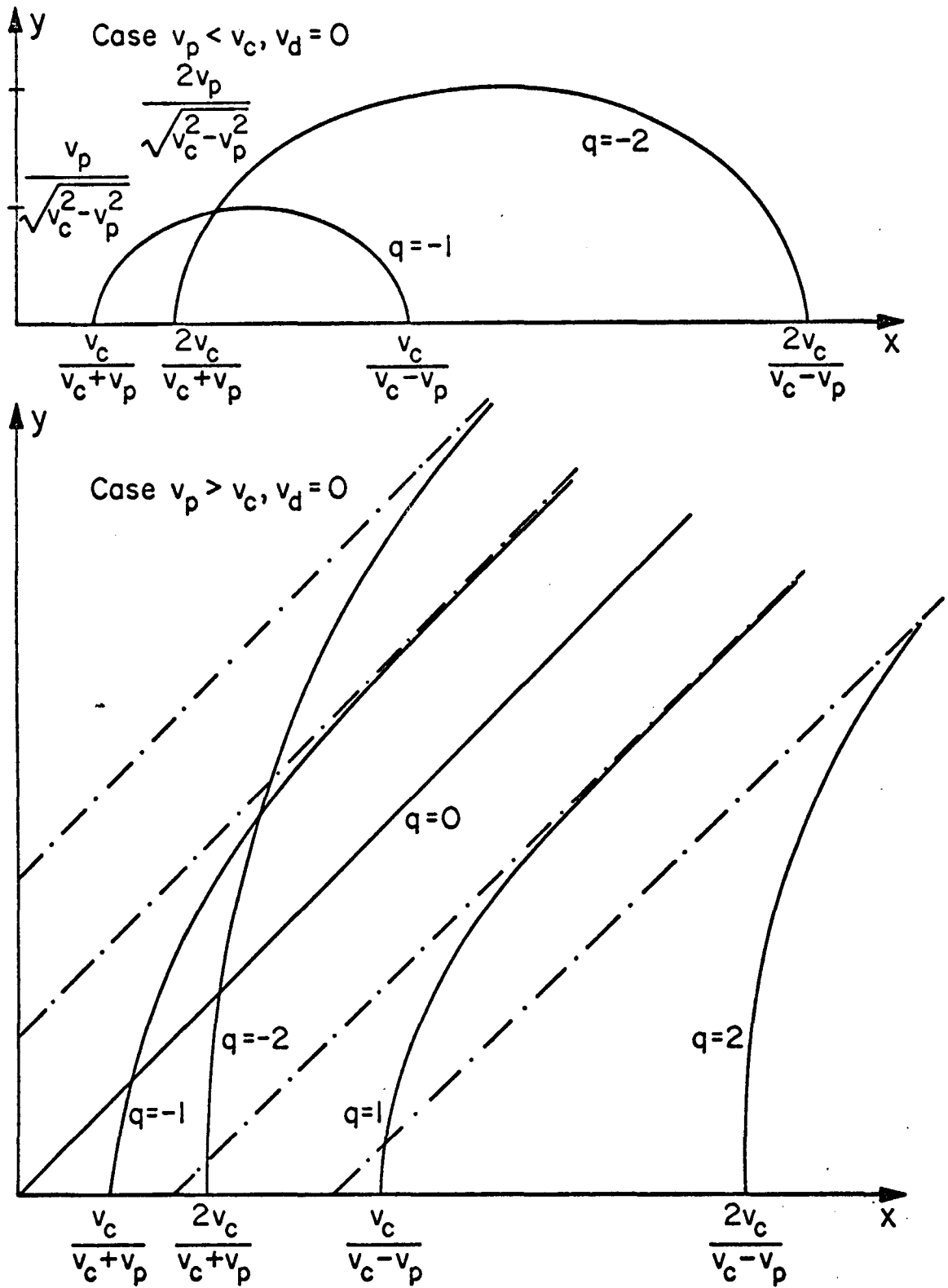

Fig. 31. Brillouin diagram for  $\epsilon_1 \rightarrow 0$

5.2.2

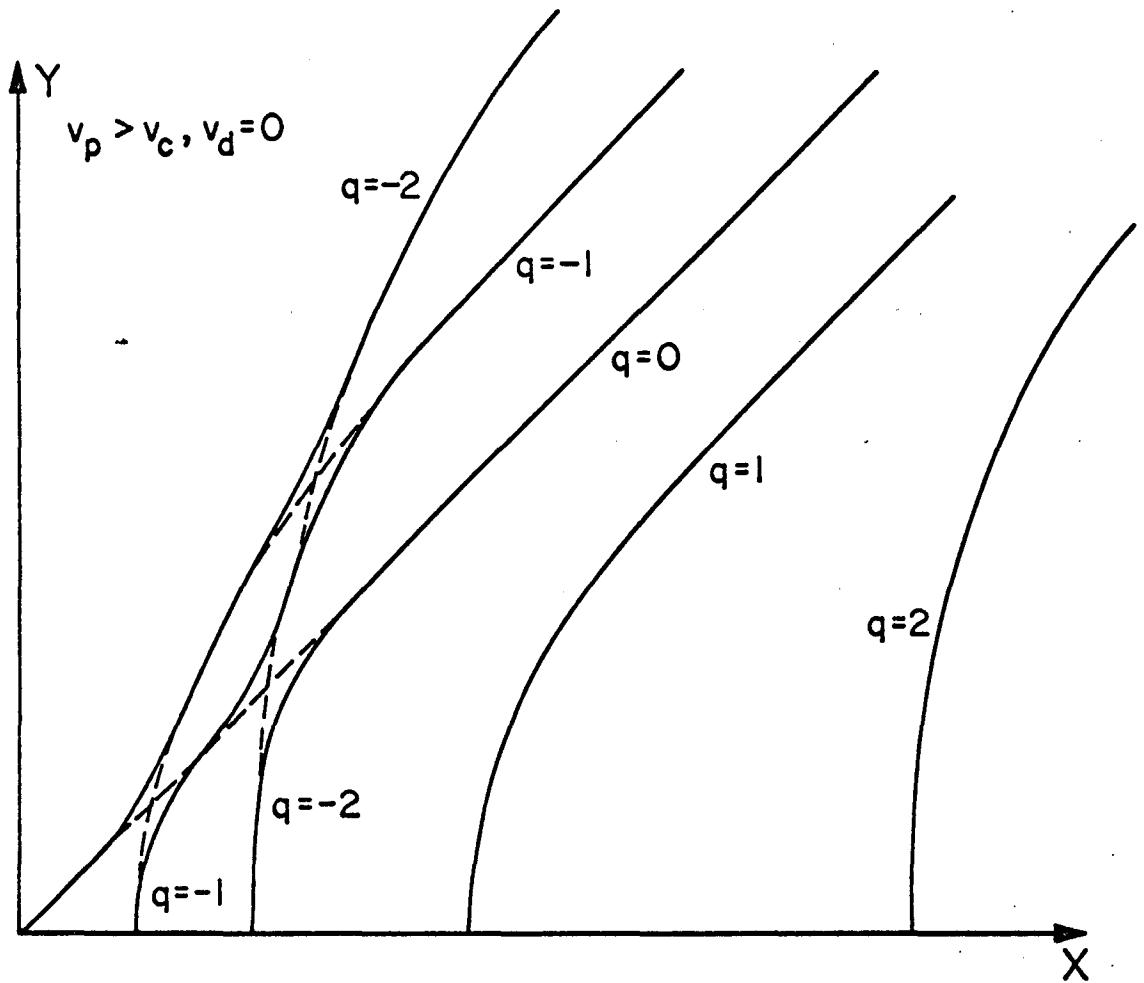
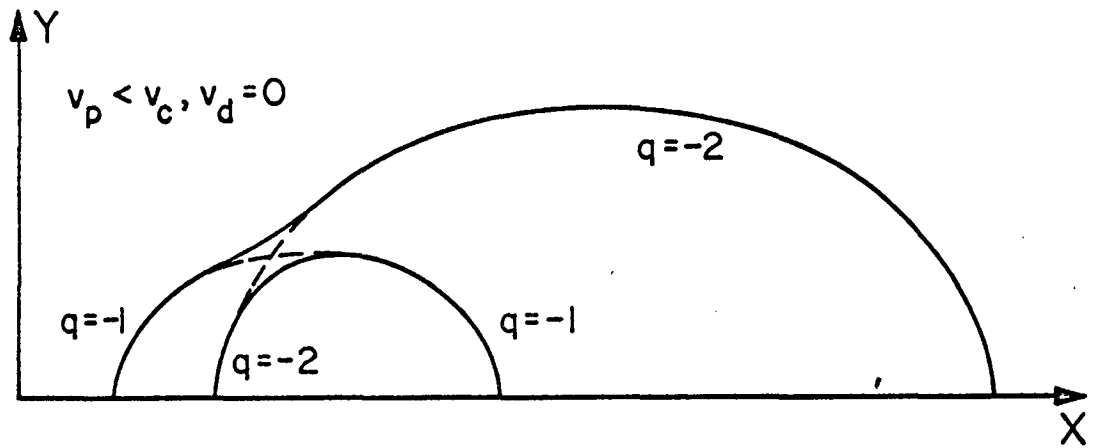

Fig. 32. Brillouin diagram for  $\epsilon_1 \neq 0$

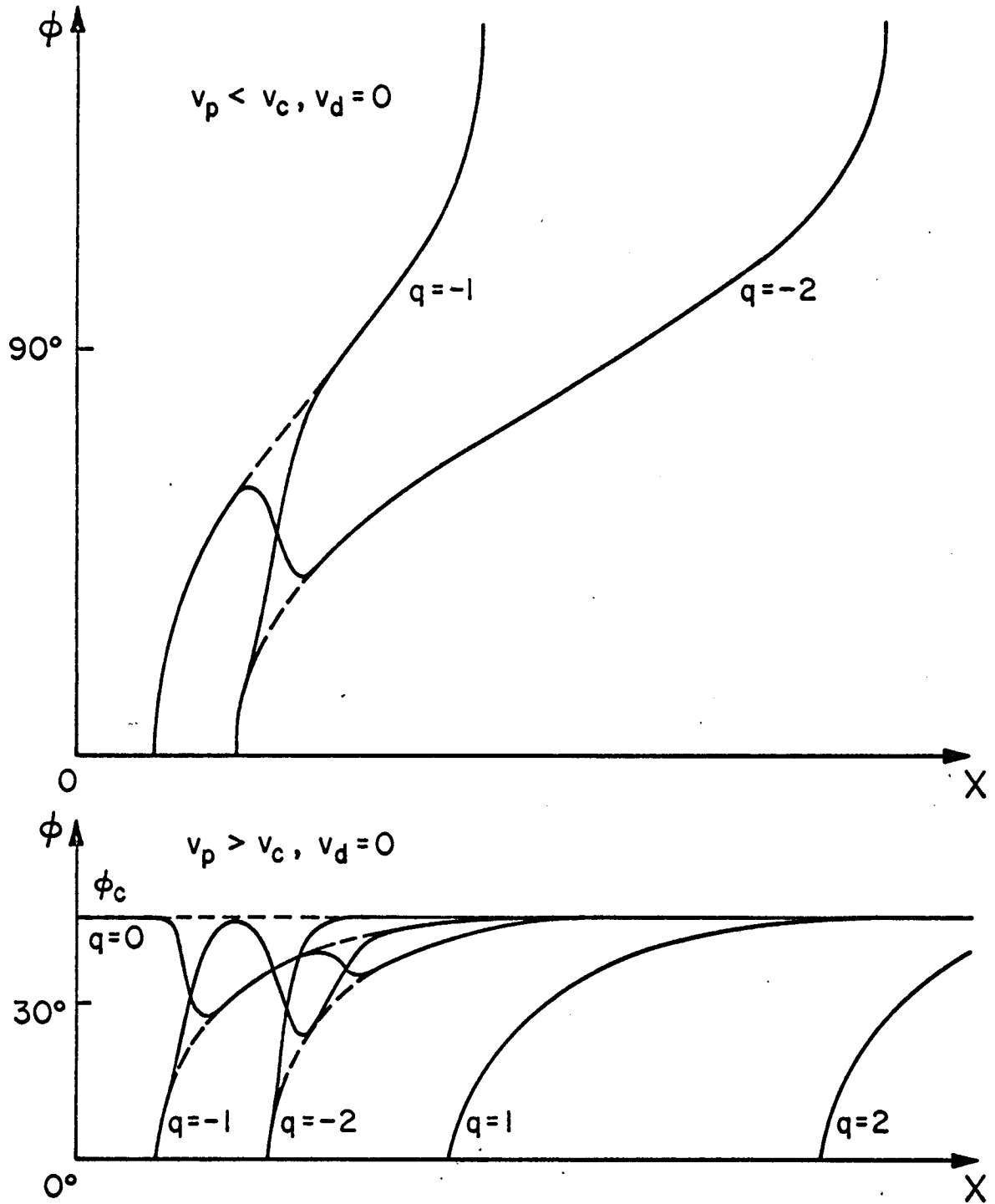

Fig. 33. Radiation angle  $\phi$  function of  $X = \omega/Kv_p$

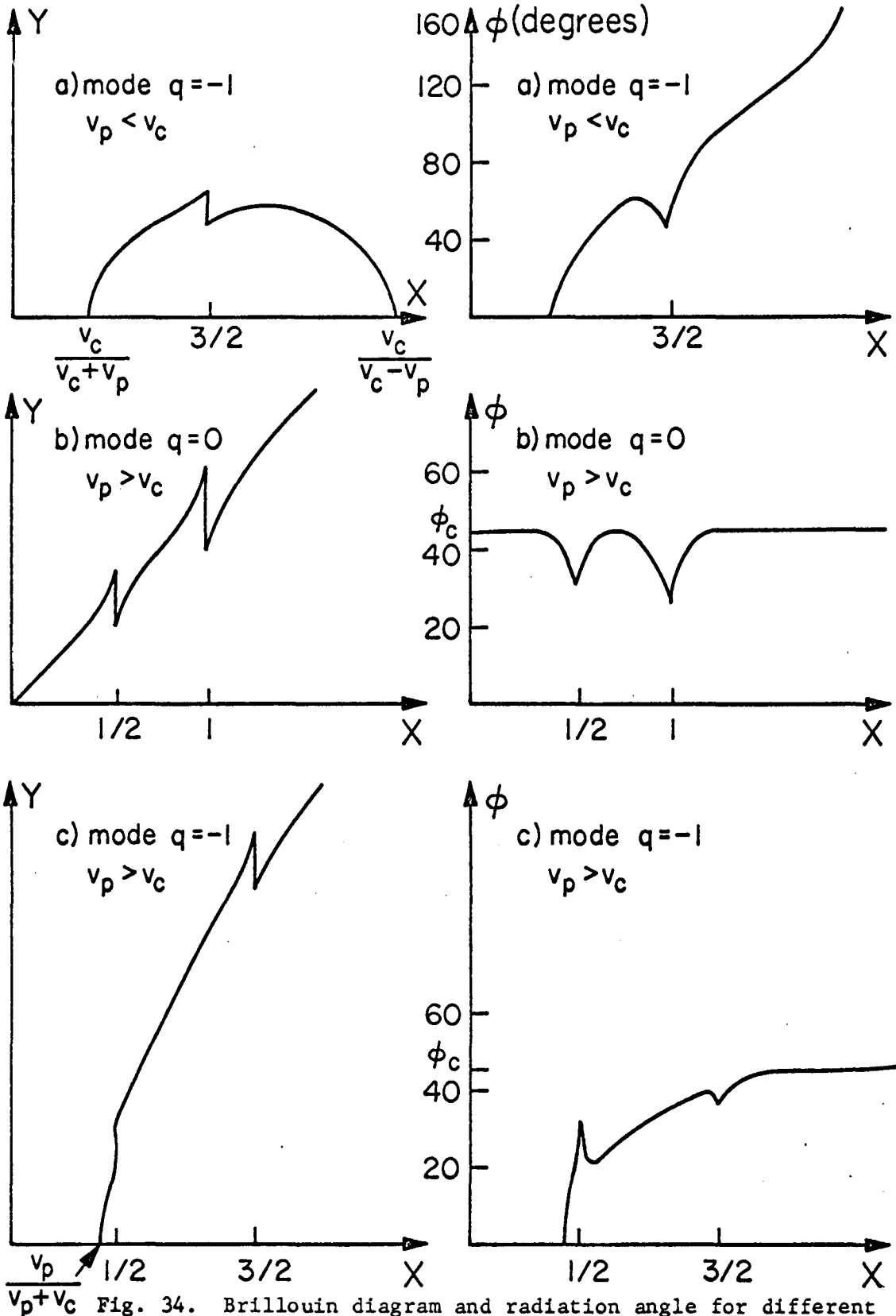

Fig. 34. Brillouin diagram and radiation angle for different modes and different cases  $\epsilon_1 \neq 0$

the results of other authors [13] who used long numerical computation of Hill's functions.

2. Moving disturbance ( $v_d \neq 0$ )

We assume  $v_d \leq v_c$

(a)  $v_p < v_c$

The corresponding Brillouin diagram is a family of ellipses for the modes  $q < 0$  which are the only ones to radiate. Each mode has a series of harmonic spectrum bands given by

$$|q|\Omega \frac{(v_c/v_d) - 1}{(v_c/v_p) - 1} + n\Omega \leq \omega_{nq} \leq |q|\Omega \frac{(v_c/v_d) + 1}{(v_c/v_p) + 1} + n\Omega$$

for  $v_p < v_d < v_c$

$$|q|\Omega \frac{(v_c/v_d) + 1}{(v_c/v_p) + 1} + n\Omega \leq \omega_{nq} \leq |q|\Omega \frac{(v_c/v_d) - 1}{(v_c/v_p) - 1} + n\Omega$$

for  $v_d < v_p < v_c$

For a certain mode and harmonic the higher part of the spectrum is radiated forward ( $\phi = 180^\circ$ ) and the lower part backward ( $\phi = 0^\circ$ ).

(b)  $v_p > v_c \geq v_d$

The corresponding Brillouin diagram is a family of hyperbolas for  $q \neq 0$  and a straight line for  $q = 0$ .

The fundamental mode ( $q = 0$ ) corresponds to the Cerenkov radiation, and the other modes will radiate inside the Cerenkov cone over a spectrum

$$\omega \geq qKv_p \frac{v_c - v_d}{v_p - v_c} \quad \text{for } q > 0$$

$$\omega \geq -qKv_p \frac{v_c + v_d}{v_c + v_p} \quad \text{for } q < 0$$

For the special case  $v_d v_p = v_c^2$  we get

$$\omega \geq |q| \frac{v_p}{v_c} \Omega \quad \text{for all } q$$

### C. Transition Radiation in Plasma

We follow the same procedure as in the previous section and we use the relations obtained in Chapter III for the isotropic plasma. Only the final results are given here.

In the limit  $N_1 \rightarrow 0$  the dispersion equation is

$$Y^2 + \left(1 - \frac{v_p^2}{v_c^2}\right) X^2 = q^2 \frac{(v_d - v_p)^2}{v_c^2 - v_p^2} - \left(\frac{\omega_{p0}}{Kv_c}\right)^2$$

where

$$x = X + q \frac{v_c^2 - v_p v_d}{v_c^2 - v_p^2}$$

$$X = \omega/Kv_p, \quad Y = \delta/K$$

As always  $v_p < v_c$  in a plasma, then the Brillouin diagram is a family of ellipses and only the modes

$$q \leq - \left| \frac{\omega_p}{Kv_c} \frac{\sqrt{v_c^2 - v_p^2}}{v_d - v_p} \right|$$

will radiate. The radiation is of the transition type.

$$q \leq -\frac{\omega_{po}}{Kv_p} \sqrt{1 - \left(\frac{v_p}{v_c}\right)^2}$$

and the spectrum bands are

$$|q|K \frac{v_p v_c^2}{v_c^2 - v_p^2} - b \leq \omega_q \leq |q|K \frac{v_p v_c^2}{v_c^2 - v_p^2} + b$$

with

$$b = v_p \left[ \left( \frac{qKv_c v_p}{v_c^2 - v_p^2} \right)^2 - \frac{\omega_{po}^2}{v_c^2 - v_p^2} \right]$$

These results (for  $v_d = 0$ ) which were obtained with a minimum amount of computation compared very well with the results obtained by other authors [14] for  $N_1 = 0.4$  and different values of  $v_p, \omega_{po}, \dots$  at the expense of long numerical computations.

VI. WAVES IN GENERAL SPACE-TIME PERIODIC MEDIA

Most of the results found in our study of the sinusoidally space-time periodic media are extended, in this chapter, to general space-time periodic media.

We assume a medium submitted to a propagating periodic disturbance, such that

$$\epsilon = \epsilon(z, t) = \epsilon_0 \epsilon_r [1 + \epsilon_1 f(Kz - \Omega t)] \quad \text{for a dielectric}$$

$$N = N(z, t) = N_0 [1 + N_1 f(Kz - \Omega t)] \quad \text{for a plasma}$$

where  $f(\eta)$  is a normalized periodic function which can be developed in a Fourier series

$$f(\eta) = \sum_{m=-\infty}^{\infty} a_m e^{im\eta}$$

A. Dielectric

1. TE waves (and magnetic dipole)

The electric field wave equation is

$$\nabla^2 E - \mu_0 \frac{\partial^2 \epsilon E}{\partial t^2} = 0$$

with  $\underline{E} = E \underline{e}_y$ . Using Floquet's theorem we can write

$$E = \sum_{n=-\infty}^{\infty} E_n e^{i\delta x + i(\kappa+nK)z - i(\omega+n\Omega)t}$$



(for the dipole  $e^{i\delta x}$  is replaced by  $H_1^{(1)}(\delta\rho)$ ). Putting the expression of  $E$  in the wave equation with

$$\epsilon = \epsilon_0 \epsilon_r \left[ 1 + \epsilon_1 \sum_{m=-\infty}^{\infty} a_m e^{im(Kz - \Omega t)} \right]$$

we get

$$\nabla^2 E = - \sum_n [\delta^2 + (\kappa + nK)^2] E_n e^{i\delta x + i(\kappa + nK)z - i\omega_n t}$$

$$\epsilon E = \epsilon_0 \epsilon_r \sum_n (E_n + \epsilon_1 \sum_m a_m E_{n-m}) e^{i\delta x + i(\kappa + nK)z - i\omega_n t}$$

$$\mu_0 \frac{\partial^2 \epsilon E}{\partial t^2} = - \sum_n \beta_n^2 (E_n + \epsilon_1 \sum_m a_m E_{n-m}) e^{i\delta x + i(\kappa + nK)z - i\omega_n t}$$

and, equating the terms with the same frequency

$$D_n E_n + \sum_{l \neq n} a_{n-l} E_l = 0 \quad (6A.1)$$

where

$$D_n = \frac{1}{\epsilon_1} \left[ 1 - \frac{\delta^2 + (\kappa + nK)^2}{\beta_n^2} \right] + a_0 \quad (6A.2)$$

or in a matrix form

$$||M|| \cdot |E| = 0 \quad (6A.3)$$

where

$$||M|| = \text{matrix with elements} \begin{cases} M_{ij} = a_{i-j} & \text{for } i \neq j \\ M_{ii} = D_i \end{cases}$$

The dispersion equation is given by

$$\text{Det } ||M|| = 0$$

the ratios  $C_n = E_n/E_0$  are found from equation 6A.3, and all the results of Chapter II can be used here.

## 2. TM waves

We take

$$H = \sum_n H_n e^{i(\kappa+nK)z + i\delta x - i\omega_n t}$$

$$\underline{E} = \sum_n (E_{nx} \underline{e}_x + E_{nz} \underline{e}_z) e^{i\delta x + i(\kappa+nK)z - i\omega_n t}$$

Putting the expressions of  $\underline{E}$  and  $H$  in Maxwell's equations, equating the terms with the same frequency, and eliminating  $H_n$ , we get

$$D_n E_{nx} + \sum_{l \neq n} a_{n-l} E_{lx} + G_n E_{nz} = 0$$

$$D'_n E_{nz} + \sum_{l \neq n} a_{n-l} E_{lz} + G_n E_{nx} = 0$$

where

$$D_n = \frac{1}{\epsilon_1} \left[ 1 - \frac{(\kappa+nK)^2}{\beta_n^2} \right] + a_0$$

$$D'_n = \frac{1}{\epsilon_1} \left[ 1 - \left( \frac{\delta}{\beta_n} \right)^2 \right] + a_0$$

$$G_n = \frac{\delta(\kappa+nK)}{\epsilon_1 \beta_n^2}$$

or in a matrix form

$$\|D\| \cdot |E_x| + \|G\| \cdot |E_z| = 0$$

$$\|D'\| \cdot |E_z| + \|G\| \cdot |E_x| = 0$$

(6A.4)

where  $||D||$ ,  $||D'||$  and  $||G||$  are matrices with elements

$$D_{ij} = D'_{ij} = a_{i-j} \quad \text{for } i \neq j$$

$$D_{ii} = D_i$$

$$D'_{ii} = D'_i$$

$$G_{ii} = G_i \quad \text{and} \quad G_{ij} = 0 \quad \text{for } i \neq j$$

Solving 6A.4 for  $E_z$  we find

$$||M|| \cdot |E_z| = 0 \quad (6A.5)$$

where

$$||M|| = ||G|| - ||D|| \cdot ||G||^{-1} \cdot ||D'||$$

Having the expression for  $||M||$ , we can apply the results found in Chapter II and Chapter V.

### 3. Sonic region

For the TE wave we have the infinite order difference equation

$$D_n E_n + \sum_{l \neq n} a_{n-l} E_l = 0 \quad (6A.6)$$

If we suppose  $a_m = 0$  for  $|m| > r$ , the characteristic equation becomes

$$a_{-r} \rho^{2r} + \dots + D \rho^r + \dots + a_{r-1} \rho + a_r = 0$$

where  $D = a_0 - \frac{R^2 - 1}{\epsilon_1}$ . From Poincare theorem, the sonic or divergence

region is equal to the regions where two roots have the same amplitude.

B. Plasma

1. TE wave

The A wave equation is

$$\nabla^2 A - \mu_o \epsilon_o \frac{\partial^2 A}{\partial t^2} - \mu_o \epsilon_o \omega_p^2(z,t) A = 0$$

This leads to

$$D_n A_n + \sum_{l \neq n} a_{n-l} A_l = 0$$

or

$$||M|| \cdot |A| = 0$$

where

$$D_n = \frac{1}{N_1} \left[ 1 - \frac{\beta_n^2 - \delta^2 - (\kappa + nK)^2}{\beta_{po}^2} \right] + a_o$$

2. TM wave

From Maxwell's and Newton's equations we get

$$D_n A_{nx} + \sum_{l \neq n} a_{n-l} A_{lx} + G_n A_{nz} = 0$$

(6A.7)

$$D'_n A_{nz} + \sum_{l \neq n} a_{n-l} A_{lz} + G_n A_{nx} = 0$$

where

$$D_n = \frac{1}{N_1} \left[ 1 - \frac{\beta_n^2 - (\kappa + nK)^2}{\beta_{po}^2} \right] + a_o$$

$$D'_n = \frac{1}{N_1} \left[ 1 - \frac{\beta_n^2 - \delta^2}{\beta_{po}^2} \right] + a_o$$

$$G_n = - \frac{\delta(\kappa+nK)}{N_1 \beta_{po}^2}$$

$$\underline{A} = \sum_n (A_{nx} \underline{e}_x + A_{nz} \underline{e}_z) e^{i(\kappa+nK)z + i\delta x - i\omega_n t}$$

$$\underline{E} = \frac{\partial \underline{A}}{\partial t}$$

The system 6A.7 can be written in a matrix form and the general results of Chapters III, IV, V are valid here.

No sonic region exists in the plasma.

## VII. CONCLUSION

In this work we investigated the problem of electromagnetic plane wave propagation and source radiation in different media (dielectric, plasma, uniaxial plasma) submitted to a traveling sinusoidal or general periodic disturbance. The sources considered were: electric dipole, magnetic dipole and uniformly moving charged particle.

The basic method of solution consists in using the Floquet theorem in conjunction with the principle of superposition to solve the wave equation or Maxwell's equations. The wave vector diagram and the Brillouin diagram were used extensively to study and explain some special effects without involved mathematical computations. Many interesting effects were studied in detail: parametric conversion and interaction for TE and TM waves, Manley-Rowe relation for oblique incidence, caustics in the dipole patterns, disturbance motion effect on the radiation angles, radiation in the cut-off cone of a uniaxial plasma, Cerenkov and transition radiation and the generalization to any space-time periodic disturbance.

Many dipole radiation patterns are given for different media and different cases.

Finally the potentials and Hertz vectors in space-time dependent media were studied and a Lorentz gauge for these media was given.

Appendix A

POTENTIALS, LORENTZ GAUGE AND HERTZ VECTORS IN A  
SPACE-TIME DEPENDENT MEDIA

Maxwell's equations in a space-time dependent media are

$$\nabla \times \underline{E} = - \frac{\partial \underline{B}}{\partial t} \quad (1)$$

$$\nabla \times \underline{H} = \frac{\partial \underline{D}}{\partial t} + \underline{I} \quad (2)$$

$$\nabla \cdot \underline{D} = \rho \quad (3)$$

$$\nabla \cdot \underline{B} = 0 \quad (4)$$

and  $\underline{D} = \epsilon(r,t) \underline{E} \quad , \quad \underline{B} = \mu_0 \underline{H} \quad (5)$

The field can be expressed in terms of a scalar, and vector potential  $\phi$  and  $\underline{A}$ , equations 1 and 4 being satisfied by

$$\underline{B} = \nabla \times \underline{A} \quad \underline{E} = -\nabla\phi - \frac{\partial \underline{A}}{\partial t} \quad (6)$$

These potentials are not unique, in fact if  $(\phi_0, \underline{A}_0)$  is a set of potentials representing a certain field, then

$$\underline{A} = \underline{A}_0 + \nabla\psi \quad \phi = \phi_0 - \frac{\partial\psi}{\partial t} \quad (7)$$

where  $\psi$  is any scalar function, will represent the same field also.

Equations 2, 3, 5, 6 lead to the coupled equations

$$\nabla \times \nabla \times \underline{A} + \mu_0 \frac{\partial}{\partial t} \left( \epsilon \frac{\partial \underline{A}}{\partial t} \right) + \mu_0 \frac{\partial}{\partial t} (\epsilon \nabla\phi) = \mu_0 \underline{I} \quad (8)$$

$$\nabla \cdot (\epsilon \nabla\phi) + \nabla \cdot \left( \epsilon \frac{\partial \underline{A}}{\partial t} \right) = -\rho \quad (9)$$

By an appropriate choice of  $\psi$ , we can choose a gauge which uncouples one of the above equations. We take

$$\nabla \cdot \underline{A} + \frac{\partial}{\partial t} (\mu_o \epsilon \phi) = 0 \quad (10)$$

(This gauge reduces to Lorentz gauge for  $\epsilon = \text{constant}$ )

then equation 8 becomes

$$\nabla \times \nabla \times \underline{A} + \mu_o \frac{\partial}{\partial t} \left( \epsilon \frac{\partial \underline{A}}{\partial t} \right) - \frac{\partial}{\partial t} \left[ \epsilon \nabla \left( \frac{1}{\epsilon} \int \nabla \cdot \underline{A} \right) \right] = \mu_o \underline{I} \quad (11)$$

So the electromagnetic field can be determined by finding the scalar and vector potentials (i.e., four scalar functions); but since they are related by equation 10, only three functions are necessary and this is where the Hertz vector comes in.

The electric Hertz vector is defined by

$$\underline{A} = -\mu_o \frac{\partial \underline{\Pi}}{\partial t} \quad \phi = \frac{1}{\epsilon} \nabla \cdot \underline{\Pi}$$

Equation 10 is automatically satisfied and, from equation 11, we get

$$\nabla^2 \underline{\Pi} - \mu_o \epsilon \frac{\partial^2 \underline{\Pi}}{\partial t^2} - \nabla \cdot \underline{\Pi} \frac{\nabla \epsilon}{\epsilon} = - \int \underline{I} \quad (12)$$

with the field outside the source volume given by

$$\underline{E} = \mu_o \frac{\partial^2 \underline{\Pi}}{\partial t^2} - \nabla \left( \frac{1}{\epsilon} \nabla \cdot \underline{\Pi} \right) = - \frac{1}{\epsilon} \nabla \times \nabla \times \underline{\Pi}$$

$$\underline{H} = - \nabla \times \frac{\partial \underline{\Pi}}{\partial t}$$

If  $\epsilon(r,t) = \epsilon(z,t)$  and  $\underline{I} = \underline{I} e_z$ , then equation 12 becomes



$$\nabla^2 \underline{\Pi} - \mu_0 \epsilon \frac{\partial^2 \underline{\Pi}}{\partial t^2} = \left[ \frac{\nabla \cdot \underline{\Pi}}{\epsilon} |\nabla \epsilon| - \int_t I \right] \underline{e}_z$$

This implies  $\underline{\Pi} = \Pi \underline{e}_z$  and the problem reduces to the determination of one scalar function  $\Pi$  from the wave equation

$$\nabla_2^2 \Pi + \epsilon \frac{\partial}{\partial z} \left( \frac{1}{\epsilon} \frac{\partial \Pi}{\partial z} \right) - \mu_0 \epsilon \frac{\partial^2 \Pi}{\partial t^2} = - \int_t I$$

where  $\nabla_2^2 = \nabla^2 - \frac{\partial^2}{\partial z^2}$  .

For the magnetic potentials we start with Maxwell's equations with magnetic sources [23, p.12]

$$\nabla \times \underline{H} = \frac{\partial \underline{D}}{\partial t} \tag{13}$$

$$\nabla \times \underline{E} = - \underline{J}_m - \frac{\partial \underline{B}}{\partial t} \tag{14}$$

$$\nabla \cdot \underline{D} = 0 \tag{15}$$

$$\nabla \cdot \underline{B} = \rho_m \tag{16}$$

From 13 and 15 we can write

$$\underline{D} = \nabla \times \underline{A}_e \qquad \underline{H} = \nabla \phi_m + \frac{\partial \underline{A}_e}{\partial t}$$

where  $\underline{A}_e$  is an electric vector potential and  $\phi_m$  is a magnetic scalar potential. These potentials are not unique and two sets of potentials  $(\phi_m^0, \underline{A}_e^0)$  or  $(\phi_m, \underline{A}_e)$  will represent the same field if they are related by

$$\underline{A}_e = \underline{A}_e^0 + \nabla \psi \tag{17}$$

$$\phi_m = \phi_m^0 - \frac{\partial \psi}{\partial t} \tag{18}$$

where  $\psi$  is any scalar function.

Taking the gauge

$$\nabla \cdot \left( \frac{\underline{A}_e}{\epsilon} \right) + \mu_o \frac{\partial \phi_m}{\partial t} = 0 \quad (19)$$

the  $\underline{A}_e$  wave equation is found as

$$\nabla \times \left( \frac{1}{\epsilon} \nabla \times \underline{A}_e \right) + \mu_o \frac{\partial^2 \underline{A}_e}{\partial t^2} - \nabla \nabla \cdot \left( \frac{\underline{A}_e}{\epsilon} \right) = - \underline{J}_m \quad (20)$$

We define a magnetic Hertz vector by

$$\underline{A}_e = \epsilon \frac{\partial \underline{M}}{\partial t} \quad \phi_m = - \frac{1}{\mu_o} \nabla \cdot \underline{M} \quad (21)$$

Equation 19 is automatically satisfied and equation 20 gives

$$\nabla^2 \underline{M} - \mu_o \frac{\partial}{\partial t} \left( \epsilon \frac{\partial \underline{M}}{\partial t} \right) - \int_t \nabla \times \left( \frac{\nabla \epsilon}{\epsilon} \times \frac{\partial \underline{M}}{\partial t} \right) = \int_t \underline{J}_m \quad (22)$$

Let us suppose  $\epsilon(r,t) = \epsilon(z,t)$ . Writing equation 22 for the three components of  $\underline{M}$  we get

$$\begin{aligned} \nabla^2 M_x - \mu_o \frac{\partial}{\partial t} \left( \epsilon \frac{\partial M_x}{\partial t} \right) - \frac{\partial}{\partial z} \left( \left| \frac{\nabla \epsilon}{\epsilon} \right| \frac{\partial M_x}{\partial t} \right) &= \int_t J_{mx} \\ \nabla^2 M_y - \mu_o \frac{\partial}{\partial t} \left( \epsilon \frac{\partial M_y}{\partial t} \right) - \frac{\partial}{\partial z} \left( \left| \frac{\nabla \epsilon}{\epsilon} \right| \frac{\partial M_y}{\partial t} \right) &= \int_t J_{my} \\ \nabla^2 M_z - \mu_o \frac{\partial}{\partial t} \left( \epsilon \frac{\partial M_z}{\partial t} \right) - \frac{\nabla \epsilon}{\epsilon} \frac{\partial}{\partial t} \left( \frac{\partial M_x}{\partial x} + \frac{\partial M_y}{\partial y} \right) &= \int_t J_{mz} \end{aligned}$$

If the source is such that

$$\underline{J}_m = J_m \underline{e}_z \quad J_{mx} = 0, \quad J_{my} = 0$$

then  $\underline{M} = M \underline{e}_z$  because there is no source term to induce the two other components, and the M wave equation becomes

$$\nabla^2 M - \mu_0 \frac{\partial}{\partial t} \left( \epsilon \frac{\partial M}{\partial t} \right) = \int_t J_m$$

This gives for the field expression outside the source volume

$$\underline{E} = \nabla \times \frac{\partial \underline{M}}{\partial t}$$

$$\underline{H} = -\frac{1}{\mu_0} \nabla \nabla \cdot \underline{M} + \frac{\partial}{\partial t} \left( \epsilon \frac{\partial \underline{M}}{\partial t} \right) = -\frac{1}{\mu_0} \nabla \times \nabla \times \underline{M}$$

Appendix B

AMPLITUDE RATIOS

We have the difference equation

$$D_n E_n + E_{n+1} + E_{n-1} = 0 \quad (1)$$

which can be written too

$$D_{n-1} E_{n-1} + E_n + E_{n-2} = 0 \quad (2)$$

These two equations give

$$E_{n+1} = -E_{n-1} - D_n E_n$$

$$E_n = -E_{n-2} - D_{n-1} E_{n-1}$$

and

$$E_{n+1} = -E_{n-1} + D_n E_{n-2} + D_n D_{n-1} E_{n-1}$$

So

$$\frac{E_{n+1}}{E_n} = -D_n + \frac{E_{n-1}}{E_{n-2} + D_{n-1} E_{n-1}} = -D_n + \frac{1}{D_{n-1} + \frac{E_{n-2}}{E_{n-1}}}$$

and

$$\frac{E_n}{E_{n+1}} = - \frac{1}{D_n - \frac{1}{D_{n-1} + \frac{E_{n-2}}{E_{n-3}}}}$$

Making the same computation for  $E_{n-2}/E_{n-3}$ , and so on, we get

$$\frac{E_n}{E_{n+1}} = - \frac{1}{D_n - \frac{1}{D_{n-1} - \frac{1}{D_{n-2} \dots}}}$$

Appendix C

STEEPEST DESCENT METHOD

Let us suppose we have to compute the integral

$$I = \int_{-\infty}^{\infty} g(t) e^{ixh(t)} dt$$

for large  $x$ , where  $h(t)$  and  $g(t)$  are analytic, and  $h(t)$  is real on the real axis.

Let  $t_0$  be defined by  $h'(t_0) = 0$ , then we have two cases:

1)  $h''(t_0) \neq 0$ ; then we have

$$h(t) = h(t_0) + \frac{(t - t_0)^2}{2!} h''(t_0) + \dots$$

and we get

$$I = \left[ \frac{2\pi}{x|h''(t_0)|} \right]^{1/2} g(t_0) e^{ixh(t_0) + i \frac{\pi}{4} \text{sign}(h'')}$$

$t_0$  is called the saddle point.

2)  $h''(t_0) = 0$ ; then

$$h(t) = h(t_0) + \frac{(t - t_0)^3}{3!} h'''(t_0)$$

and

$$I = \sqrt{3} \Gamma\left(\frac{4}{3}\right) \left[ \frac{6}{x|h'''(t_0)|} \right]^{1/3} g(t_0) e^{ixh(t_0)}$$

Appendix D

CAUSTICS

The caustic effect can be explained from the wave vector diagram without any mathematical computations. This diagram shows directly the group and phase velocity directions. For instance, in Fig. a, the radiated wave which corresponds to the point A has a phase velocity vector  $\underline{v}_p$  such that  $\phi = (\underline{v}_p, \underline{z})$  and a group velocity vector  $\underline{v}_g$  such that  $\theta = (\underline{v}_g, \underline{z})$ .

Inversely, if we want to find the points on the wave vector diagram which radiate in the direction  $\theta$ , we have to find the points on the diagram where the normal to the tangent makes an angle  $\theta$  with the  $k_z$  axis.

For the diagram b, there are three points which radiate in the  $\theta_0$  direction, therefore we get a large field in that direction.

If there is an inflection point in the diagram (see Fig. c), then all the section around that point will radiate in one direction  $\theta_c$  and this gives a very large field for  $\theta = \theta_c$ . This is the caustic effect.

The caustic effect can be compared to the cone effect in a uniaxial plasma which has the diagram in Fig. d. We see that a large section of the diagram radiates in a direction  $\theta_p$  which is the cone angle, and that is why the field is very large on the cone surface.

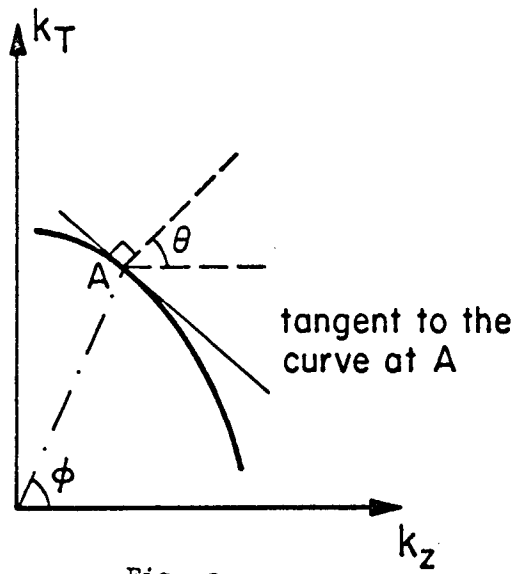

Fig. a

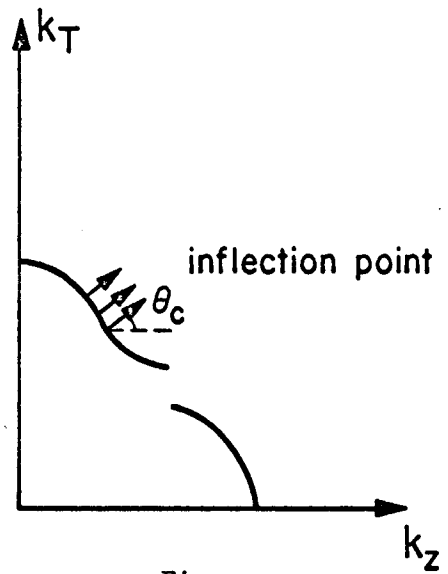

Fig. c

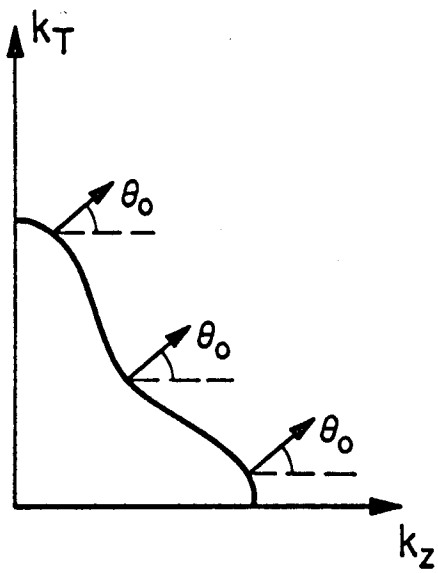

Fig. b

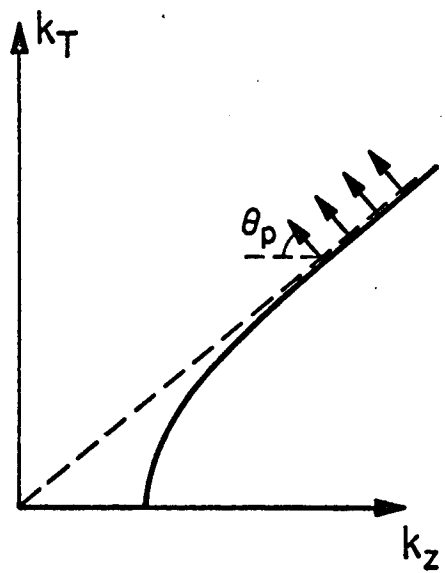

Fig. d



References

1. W. R. Klein and B. D. Cook, "Unified approach to ultrasonic light diffraction", IEEE Transactions SU-14, 123-134 (1967).
2. S. T. Peng and E. S. Cassedy, "Scattering of light waves at boundaries of parametrically-modulated media", Proc. Symp. of Modern Optics, Polytechnic Press, 1967, pp. 299-342.
3. A. Korpel, "Visualization of the cross-section of a sound beam by Bragg diffraction of light", Appl. Phys. Lett. 9, 425-427 (1966)
4. H. V. Hance, J. K. Parks and C. S. Tsai, "Optical imaging of a complex ultrasonic field by diffraction of a laser beam", J. Appl. Phys. 38, 1981-1983 (1967).
5. B. R. Rao and W. A. Saxton, "Bragg scattering of electromagnetic waves by moving striations in a plasma column", presented at the 1968 Spring URSI Meeting in Washington.
6. D. E. Holberg and K. S. Kunz, "Parametric properties of fields in a slab of time-varying permittivity," IEEE Transactions AP-14, 183-194 (1966).
7. T. Tamir, H. C. Wang and A. A. Oliner, "Wave propagation in sinusoidally stratified dielectric media", IEEE Transactions MTT-12, 323-335 (1964).
8. C. Yeh, K. F. Casey and Z. A. Kaprielian, "Transverse magnetic wave propagation in sinusoidally stratified dielectric media", IEEE Transactions MTT-13, 297-302 (1965).
9. T. Tamir and H. C. Wang, "Scattering of electromagnetic waves by a sinusoidally stratified half-space", Canadian J. Phys. 44, 2073-2093 (1966).
10. K. F. Casey, J. R. Mathis and C. Yeh, "Wave propagation in sinusoidally stratified plasma", J. Math. Phys. 10, 891-897 (1969).
11. K. F. Casey, "Dipole radiation in a periodically stratified medium" Canadian J. Phys. 46, 2543-2551 (1968).

12. D. B. Singer and T. Tamir-Berman, "Diffraction of light from a filamentary source by parallel acoustic wave fronts", J. Opt. Soc. America 60, 1640-1653 (1970).
13. K. F. Casey, C. Yeh and Z. A. Kaprielian, "Cerenkov radiation in inhomogeneous periodic media", Phys. Rev. 140, B768-B775 (1965).
14. K. F. Casey and C. Yeh, "Transition radiation in a periodically stratified plasma", Phys. Rev. A-2, 810-818 (1970).
15. J. C. Simon, "Action of a progressive disturbance on a guided electromagnetic wave", IRE Trans. MTT-8, 18-29 (1960).
16. D. S. Cassedy and A. A. Oliner, "Dispersion relations in time-space periodic media", Proc. of IEEE 51, 1342-1359 (1963).
17. K. A. Barsukov, "Theory of waveguides with nonstationary filling" Radio Eng. & Electronic Phys. (Trans. from Russian) 9, 967-971 (1964).
18. R. Rao, "Electromagnetic wave propagation in a dielectric medium space-time modulated by a nonlinear pump wave," Proc. of IEEE 56, 1630-1631 (1968).
19. P. Bernardi and A. Salsamo, "Wave propagation in rectangular waveguides having a time-space periodically modulated side-wall", URSI Symposium on Electromagnetic Waves 1968, Alta Frequenza, pp. 77-81.
20. J. Askne, "Wave reflection from and propagation in a pumped semi-infinite medium", URSI Symposium on Electromagnetic Waves 1968, Alta Frequenza, pp. 216-220.
21. L. M. Milne-Thompson, Calculus of Finite Differences, London, Macmillan (1933).
22. W. Magnus, Hill's Equations, John Wiley (1966).
23. C. H. Papas, Theory of Electromagnetic Wave Propagation, McGraw-Hill (1965).

## DOCUMENT CONTROL DATA - R &amp; D

(Security classification of title, body of abstract and indexing annotation must be entered when the overall report is classified)

1. ORIGINATING ACTIVITY (Corporate author)		2a. REPORT SECURITY CLASSIFICATION	
California Institute of Technology Pasadena, California 91109		Unclassified	
3. REPORT TITLE		2b. GROUP	
ELECTROMAGNETIC WAVE PROPAGATION AND SOURCE RADIATION IN SPACE-TIME PERIODIC MEDIA			
4. DESCRIPTIVE NOTES (Type of report and inclusive dates)			
Scientific Interim			
5. AUTHOR(S) (First name, middle initial, last name)			
Charles Elachi			
6. REPORT DATE	7a. TOTAL NO OF PAGES	7b. NO. OF REFS	
November 1971	140	23	
8a. CONTRACT OR GRANT NO	8b. ORIGINATOR'S REPORT NUMBER(S)		
AFOSR-70-1935	Antenna Lab Technical Report No. 61		
b. PROJECT NO	9b. OTHER REPORT NO(S) (Any other numbers that may be assigned this report)		
9768-02	AFOSR-TR-72-0175		
c. 61102F			
d. 681305			
10. DISTRIBUTION STATEMENT			
Approved for public release; distribution unlimited.			
11. SUPPLEMENTARY NOTES		12. SPONSORING MILITARY ACTIVITY	
TECH, OTHER		A.F. Office of Scientific Research (NE) 1400 Wilson Blvd. Arlington, Virginia 22209	
13. ABSTRACT			
<p>The electromagnetic wave equations for the fields, potentials, and Hertz vectors are derived and a Lorentz gauge is given for space-time dependent media. Electromagnetic wave propagation, electric and magnetic dipole radiation, and Cerenkov and transition radiation in sinusoidally space-time periodic dielectric, plasma, and uniaxial plasma are studied and numerous radiation patterns are given. Finally the study is extended to general space-time periodic media, (i.e., <math>\epsilon = \epsilon_o \epsilon_r [1 + \epsilon_1 f(Kz - \Omega t)]</math> where <math>f(\xi)</math> is a periodic function.)</p>			

14. KEY WORDS	LINK A		LINK B		LINK C	
	ROLE	WT	ROLE	WT	ROLE	WT
Space-time periodic dielectric, plasma and uniaxial plasma  Dipole radiation Cerenkov Radiation Lorentz gauge Hertz vectors						