

# Guest Lectures for Dr. MacFarlane's EE3350 — Part Deux

Michael Plante

Mon., 08-30-2010

Write name in corner. Point out this is a review, so I will go faster. Remind them to go listen to online lecture about “getting an A in engineering.”

## 1. Dirac Delta

$\delta(t)$  is the Dirac delta. It is even, has unit area, and has infinite amplitude. It doesn't generally make sense outside of an integral. In particular, the argument of the delta should be linear in the variable of integration. Basic properties:

$$\delta(t) = \delta(-t), \quad \int_{-\infty}^{\infty} \delta(t) dt = 1, \quad \delta(t) = \begin{cases} 0 & t < 0 \\ \infty & t = 0 \\ 0 & t > 0 \end{cases}$$

Take a rectangle of width  $A$  and height  $1/A$ , centered on the origin, as shown in Figure 1.1. In the limit as  $A \rightarrow 0$ , we get our delta.

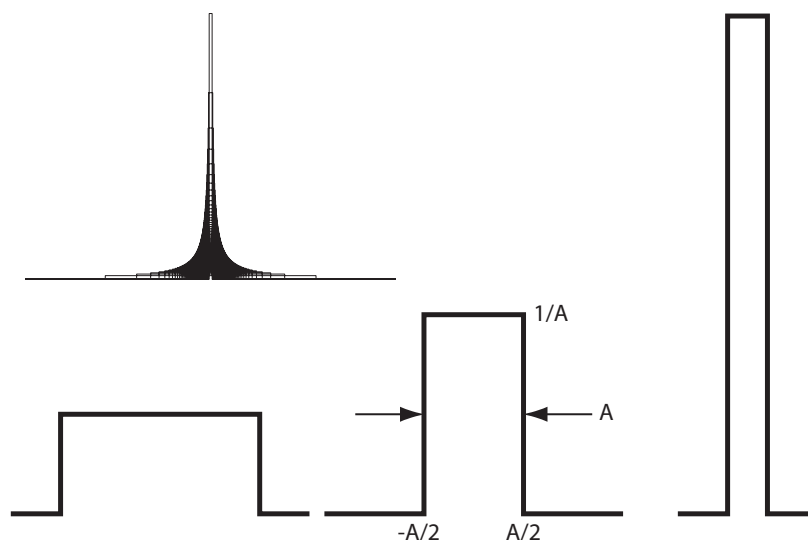

Figure 1.1: Dirac Delta — Progression

Our sifting property diagram is shown in Figure 1.2.

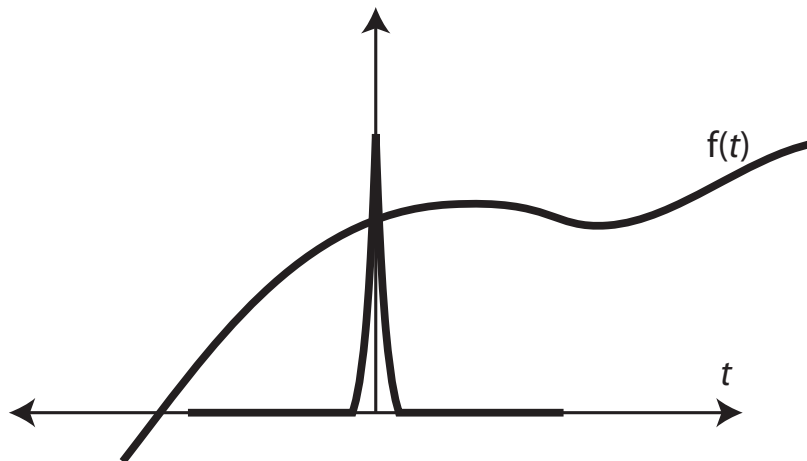

Figure 1.2: Sifting Property

We can ignore regions not immediately over the delta:

$$\int_{-\infty}^{\infty} f(t)\delta(t) dt = \int_{-\infty}^{0^-} f(t) \cdot 0 dt + \int_{0^-}^{0^+} f(t)\delta(t) dt + \int_{0^+}^{\infty} f(t) \cdot 0 dt$$

Now, because  $f(t)$  is continuous in the near vicinity of  $t = 0$ , we can take it as approximately constant for a small region. Then:

$$\int_{-\infty}^{\infty} f(t)\delta(t) dt = \int_{0^-}^{0^+} f(t)\delta(t) dt = f(0) \underbrace{\int_{0^-}^{0^+} \delta(t) dt}_1 = f(0)$$

Similarly,

$$\int_{-\infty}^{\infty} f(t)\delta(t - T) dt = f(T)$$

Also, as illustrated in Figure 1.3,

$$\int_{-\infty}^t \delta(\tau) d\tau = u(t), \quad \int_{-\infty}^t u(\tau) d\tau = tu(t), \quad \delta'(t) \triangleq \frac{d}{dt}\delta(t)$$

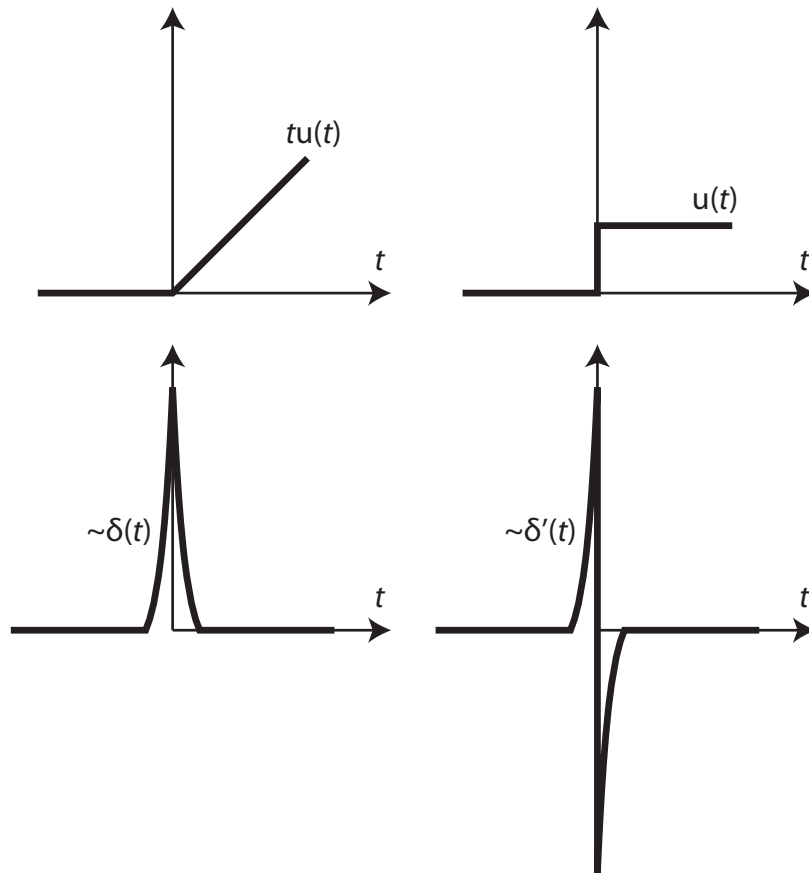

Figure 1.3: Delta, its Derivative, and its First Two Integrals

The Kronecker delta is:

$$\delta[n] = \begin{cases} 1 & n = 0 \\ 0 & n \neq 0 \end{cases}$$

## 2. LTI and Transfer Functions

We like to use the delta to characterize linear systems. Take  $x(t)$  as the input, and  $y(t)$  as the output, as shown in Figure 2.1. The impulse response  $h(t)$  will be introduced shortly.

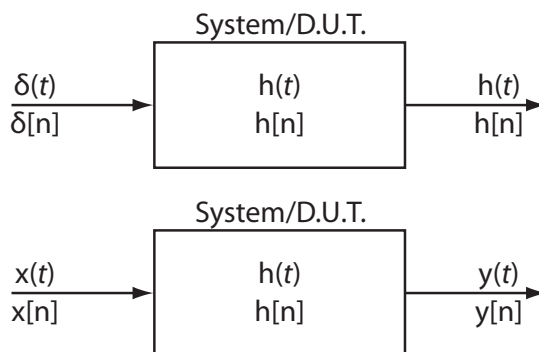

Figure 2.1: System, Input, Output, Impulse Response

Time-invariance implies that  $x(t-a)$  yields  $y(t-a)$  (i.e., both have their time origin shifted by the same amount). If this holds true for any  $x$  and  $a$ , then the system is time-invariant.

If  $x_1(t)$  is input, and we obtain an output of  $y_1(t)$ , and ditto for  $x_2/y_2$ , then linearity implies that  $ax_1(t) + bx_2(t)$  should yield  $ay_1(t) + by_2(t)$ . If this holds true for any  $x$ ,  $a$ , and  $b$ , then the system is linear. Systems that are both linear and time-invariant get the acronym LTI, since we refer to them so often.

If  $x(t) = \delta(t)$  is input into a continuous linear system, the output is  $h(t)$ , the impulse response. If  $x[n] = \delta[n]$  is input into a discrete linear system, the output is  $h[n]$ , the impulse response.

If an arbitrary  $x(t)$  is input into the linear system, it is convolved with the impulse response to obtain the output. So, for the discrete case, we have:

$$y[n] = x[n] \otimes h[n] = \sum_{k=-\infty}^{\infty} x[k]h[n-k] = \sum_{p=-\infty}^{\infty} x[n-p]h[p] \quad (p = n - k)$$

and for the continuous case, we have:

$$y(t) = x(t) \otimes h(t) = \int_{-\infty}^{\infty} x(\tau)h(t-\tau) d\tau = \int_{-\infty}^{\infty} x(t-\tau')h(\tau') d\tau' \quad (\tau' = t - \tau)$$

In the above, it's not *required* to choose a different dummy variable name when you do a change of variables, but it often helps with clarity and checking your work. I won't be doing any discrete examples, but, if the continuous example (integral) looks difficult, you're in luck...

### 3. Convolution Examples

#### 3.1 Boxcar and Sine

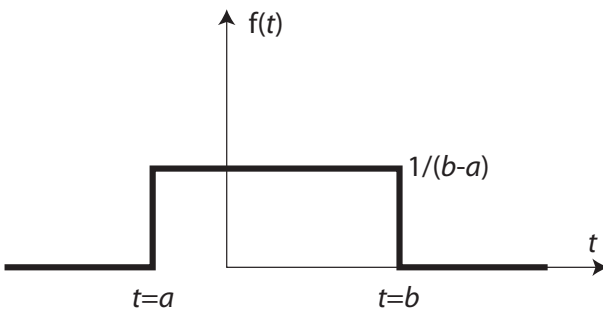

Figure 3.1: Unit-area Boxcar

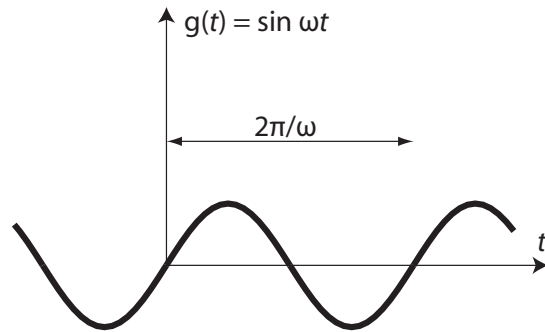

Figure 3.2: Sine Wave

As shown in Figures 3.1 and 3.2,

$$f(t) = \frac{1}{b-a} [u(t-a) - u(t-b)], \quad b > a$$

$$g(t) = \sin \omega t, \quad \omega > 0$$

Convolve  $f(t)$  and  $g(t)$ :

$$\begin{aligned} \int_{-\infty}^{\infty} f(\tau) g(t-\tau) d\tau &= \int_a^b \frac{g(t-\tau)}{b-a} d\tau = \int_a^b \frac{\sin \omega(t-\tau)}{b-a} d\tau = \frac{1}{\omega(b-a)} [\cos \omega(t-b) - \cos \omega(t-a)] \\ &= \frac{2}{\omega(b-a)} \sin \frac{\omega(b-a)}{2} \sin \left[ \omega t - \frac{\omega(a+b)}{2} \right] = \text{sinc} \frac{\omega(b-a)}{2} \sin \left[ \omega t - \frac{\omega(a+b)}{2} \right] \end{aligned}$$

First note that when  $b = -a$ , the phase offset on the final sinusoid disappears:  $\text{sinc } b\omega \sin \omega t$ . So the symmetry of the boxcar about the origin leads to a lack of a phase offset. This is a special case of  $(a + b) / 2$  being a multiple of  $2\pi/\omega$ , or, equivalently, the center of the boxcar being a multiple of the period of the sinusoid. This could be interpreted as the sinusoid being shifted by the center of the boxcar, but, when that's a multiple of  $2\pi$  radians, it is unnoticeable.

It is interesting to note what happens in the limit as  $a$  and  $b$  become close:

$$\lim_{b \rightarrow a} (f \otimes g) = \sin \omega (t - b)$$

The sinusoid has just been shifted to the right by  $b$  units of time. This is precisely what would have happened if  $f$  had instead been a Dirac delta at  $b$ :  $f(t) \rightarrow \delta(t - b)$ .

### 3.2 Triangle and One-Sided Exponential

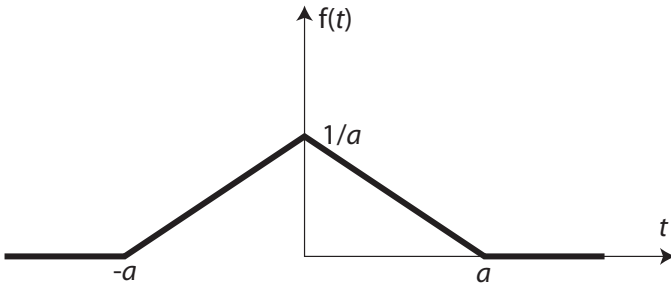

Figure 3.3: Unit-Area Triangle

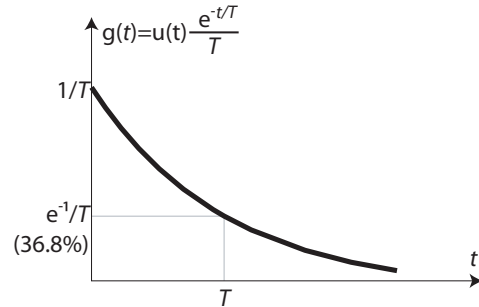

Figure 3.4: Unit-Area One-Sided Exponential

As shown in Figures 3.3 and 3.4,

$$f(t) = \begin{cases} \frac{t}{a^2} + \frac{1}{a} & -a \leq t \leq 0 \\ \frac{-t}{a^2} + \frac{1}{a} & 0 \leq t \leq a \\ 0 & \text{otherwise} \end{cases}, \quad a > 0$$

$$g(t) = T^{-1} e^{-t/T} u(t), \quad T > 0$$

Convolve  $f(t)$  and  $g(t)$ :

$$\begin{aligned} \int_{-\infty}^{\infty} f(\tau) g(t - \tau) d\tau &= \frac{1}{a^2 T} \int_{-a}^0 (a + \tau) e^{-(t-\tau)/T} u(t - \tau) d\tau + \frac{1}{a^2 T} \int_0^a (a - \tau) e^{-(t-\tau)/T} u(t - \tau) d\tau \\ &= \frac{e^{-t/T}}{a^2 T} \int_{\min(-a, t)}^{\min(0, t)} (a + \tau) e^{\tau/T} d\tau + \frac{e^{-t/T}}{a^2 T} \int_{\min(0, t)}^{\min(a, t)} (a - \tau) e^{\tau/T} d\tau \\ &= \frac{e^{-t/T}}{a^2} \left[ (a + \tau - T) e^{\tau/T} \right]_{\min(-a, t)}^{\min(0, t)} + \frac{e^{-t/T}}{a^2} \left[ (a - \tau + T) e^{\tau/T} \right]_{\min(0, t)}^{\min(a, t)} \\ &= \frac{e^{-t/T}}{a^2} \cdot \begin{cases} -2T + T e^{-a/T} + T e^{a/T} & t \geq a \\ -2T + T e^{-a/T} + (a - t + T) e^{t/T} & a \geq t \geq 0 \\ T e^{-a/T} + (a + t - T) e^{t/T} & 0 \geq t \geq -a \\ 0 & -a \geq t \end{cases} \end{aligned}$$

This result has a maximum at  $t = -a + T \ln(2e^{a/T} - 1)$ , with  $t$  in the interval from 0 to  $a$ . In the limit as  $a \rightarrow 0$ , an intermediate result is:

$$\begin{cases} T^{-1}e^{-t/T} & t > a \\ \text{undefined} & a \gg |t| \geq 0 \\ 0 & -a > t \end{cases} \rightarrow \begin{cases} T^{-1}e^{-t/T} & t > 0 \\ \text{undefined} & t = 0 \\ 0 & 0 > t \end{cases}$$

Other than at the origin, this is effectively equal to  $g(t)$ . In other words,  $f(t) \rightarrow \delta(t)$  as  $a \rightarrow 0$ . Note that the limit in the middle case is dependent on the relative way  $a$  and  $t$  approach zero, so it is undefined. For example, on the assumption that  $t$  approaches 0 much faster, then it gives  $1/2T$ , but if we instead approach along the line  $t = a$ , the limit changes to 0. This is not surprising, since some definitions of the unit step are undefined at the origin.

If we instead take the limit as  $T$  approaches 0, we obtain:

$$\begin{cases} 0 & |t| \geq a \\ (a-t)a^{-2} & a \geq t \geq 0 \\ (a+t)a^{-2} & 0 \geq t \geq -a \end{cases}$$

This is clearly just  $f(t)$ . What's interesting here is that  $g(t)$ , which is clearly not even (for  $T$  strictly positive, anyway), appears to have the same effect as the even function  $\delta(t)$  as  $T$  approaches 0. It is not clear if this happens for every  $f(t)$ .

### 3.3 Windowed Ramp and Windowed Cosine

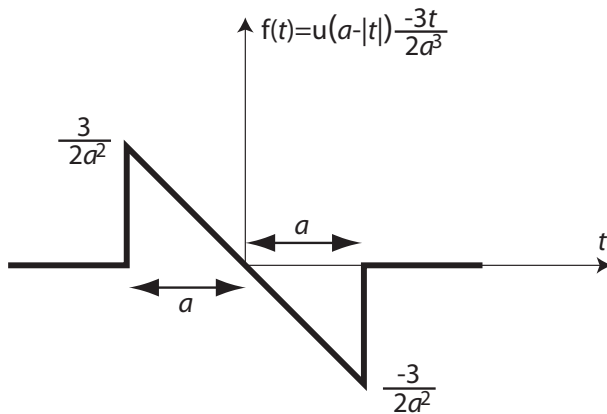

Figure 3.5: Truncated Ramp,  
Approximation of Unit  
Doublet

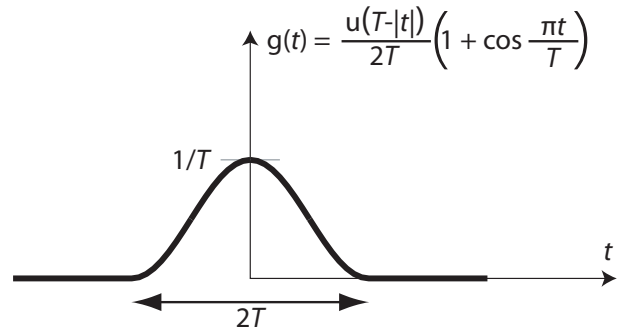

Figure 3.6: Truncated Cosine

As shown in Figures 3.5 and 3.6,

$$f(t) = \frac{-3t}{2a^3} u(a - |t|) \quad a > 0$$

$$g(t) = \left(1 + \cos \frac{\pi t}{T}\right) \frac{u(T - |t|)}{2T}, \quad T > 0$$

Convolve  $f(t)$  and  $g(t)$ :

$$\int_{-\infty}^{\infty} f(t-\tau) g(\tau) d\tau = \frac{-3}{4a^3T} \int_{-T}^T (t-\tau) u(a-|t-\tau|) \left(1 + \cos \frac{\pi\tau}{T}\right) d\tau$$

We already accounted for the step in  $g(t)$  by our choice of integration limits. We can account for the step remaining in the integrand by also forcing  $t+a > \tau > t-a$ . Both sets of limits can be easily enforced by using the method we found before.

But we also need to ensure that  $t+a > -T$  and  $T > t-a$ , both of which follow from transitivity. If that is not obvious, we can equivalently state that this amounts to clamping the original integration limits of  $\pm T$  to the range between  $t-a$  and  $t+a$ , rather than merely clamping from one side, as before. So:

$$\begin{aligned} \int_{-\infty}^{\infty} f(t-\tau) g(\tau) d\tau &= \frac{-3}{4a^3T} \int_{\max(\min(-T, t+a), t-a)}^{\max(\min(T, t+a), t-a)} (t-\tau) \left(1 + \cos \frac{\pi\tau}{T}\right) d\tau \\ &= \frac{-3}{4a^3T} \left[ \tau \left(t - \frac{\tau}{2}\right) + \frac{T}{\pi^2} \left(-T \cos \frac{\pi\tau}{T} + \pi(t-\tau) \sin \frac{\pi\tau}{T}\right) \right]_{\max(\min(-T, t+a), t-a)}^{\max(\min(T, t+a), t-a)} \end{aligned}$$

While this could be evaluated entirely in terms of step functions, the results would not be terribly clear. Instead we'll consider that there are really just six possibilities:

1.  $\begin{array}{ccccccc} & & -T & t-a & t+a & T & \\ & & & & & & \end{array}$
2.  $\begin{array}{ccccccc} & t-a & -T & & & T & t+a \\ & & & & & & \end{array}$
3.  $\begin{array}{ccccccc} & t-a & -T & t+a & & T & \\ & & & & & & \end{array}$
4.  $\begin{array}{ccccccc} & & -T & & t-a & T & t+a \\ & & & & & & \end{array}$
5.  $\begin{array}{ccccccc} t-a & t+a & -T & & & T & \\ & & & & & & \end{array}$
6.  $\begin{array}{ccccccc} & & -T & & & T & t-a & t+a \\ & & & & & & & \end{array}$

The results are then:

$$\begin{cases} \frac{3}{2a^3\pi^2} \sin \frac{\pi t}{T} \left( a\pi \cos \frac{a\pi}{T} - T \sin \frac{a\pi}{T} \right) & -T \leq t-a \leq t+a \leq T \\ \frac{-3t}{2a^3} & t-a \leq -T \leq T \leq t+a \\ \frac{1}{8a^3\pi^2T} \left[ 3a^2\pi^2 + 6T^2 - 3\pi^2(t+T)^2 + 6T \left( T \cos \frac{\pi(a+t)}{T} + a\pi \sin \frac{\pi(a+t)}{T} \right) \right] & t-a \leq -T \leq t+a \leq T \\ \frac{-1}{8a^3\pi^2T} \left[ 3a^2\pi^2 + 6T^2 - 3\pi^2(t-T)^2 + 6T \left( T \cos \frac{\pi(a-t)}{T} + a\pi \sin \frac{\pi(a-t)}{T} \right) \right] & -T \leq t-a \leq T \leq t+a \\ 0 & t-a \leq t+a \leq -T \leq T \\ 0 & -T \leq T \leq t-a \leq t+a \end{cases}$$

Note that this is only really 5 different regions: for any given values of  $a$  and  $T$ , either case 1 can occur or case 2 can, but not both, determined entirely by whether  $a$  or  $T$  is bigger.

In the limit as  $T$  approaches 0, we obtain for each respective case:

$$\begin{cases} \text{undefined} & a < T \rightarrow 0 \\ f(t) & |t| < a \\ \text{undefined} & t \rightarrow -a \\ \text{undefined} & t \rightarrow a \\ 0 & t < -a \\ 0 & t > a \end{cases}$$

For much the same reasons as in the previous section, cases 3 and 4 are undefined. Case 1 oscillates close to the limit. But nevertheless we have that  $g(t)$  approaches a Dirac delta once again.

If we instead take the limit as  $a$  approaches 0, we obtain:

$$\begin{cases} g'(t) & |t| < T \\ \text{undefined} & T < a \rightarrow 0 \\ 0 & t \rightarrow -T \\ 0 & t \rightarrow T \\ 0 & t < -T \\ 0 & t > T \end{cases}$$

In case 2, the limit is only defined along a particular path, and is infinite otherwise. Regardless of whether the limit in cases 3 and 4 exists or not, those are just individual points, so, like before, they do not matter much. In this case, we have  $f(t) \rightarrow \delta'(t)$ , the unit doublet. The action is to take the derivative of the function it is convolved with.

If time to write: here's a proof (I think?) that the limit is, in fact, 0 in case 3; case 4 should be similar. Because  $f(t)$  and  $g(t)$  are centered at zero, and no other (unnamed) constants are meaningful, we can, without loss of generality, take  $T = 1$ . (To justify this in a different way, scale  $t$  and  $a$  by whatever quantity you had to use to get  $T$  down to 1.) Now change variables such that  $t = -T + \frac{r}{\pi\sqrt{2}} \cos\left(\theta + \frac{\pi}{4}\right)$  and  $a = \frac{r}{\pi\sqrt{2}} \sin\left(\theta + \frac{\pi}{4}\right)$ . Choosing  $\theta \in \left[0, \frac{\pi}{2}\right]$ ,  $r > 0$  will allow us to let  $(t + T, a)$  approach the origin, with  $t + T$  bounded by  $\pm a$ , in line with the constraints defining case 3. Then we have for the new result in this interval (up to a constant factor):

$$\frac{\csc^3\left(\theta + \frac{\pi}{4}\right)}{2r^3\sqrt{2}} \left[ 2 - 2\cos(r\cos\theta) + r^2\sin\theta\cos\theta - r\sin(r\cos\theta)(\cos\theta + \sin\theta) \right]$$

Now it is not sufficient simply to take the limit as  $r$  approaches zero, because  $\theta$  must be allowed to vary arbitrarily as a function of  $r$  as that limit is taken: if any  $\theta(r)$  failed to reach the same limit, the limit would not exist. In other words, that naïve approach would always take a radial line into the origin, which is insufficiently general. Now we wish to test the idea that the limit is zero. For small enough  $r$ , this quantity is nonnegative for all  $\theta$ , so we need to find the  $\theta$  that maximizes it for every  $r$ . This happens to simply occur when  $\theta = 0$ , independently of  $r$ , provided  $r$  is small enough: this gives an upper bound. Then, for any maximum error from zero, we merely need to show we can find an  $r_0$  such that for all positive  $r < r_0$ , this quantity will be  $\leq$  the target error. Looking at  $\theta = 0$  as our upper bound, we obtain:

$$\frac{2 - 2\cos r - r\sin r}{r^3}$$

But this is a monotonically-increasing odd-symmetric function about the origin for small  $r$ , so it is invertible and we can solve for such an  $r_0$ , and so the limit converges in case 3.