

Laboratory 1
CSE 3381
Logic Gate Truth Tables

This experiment will serve as an introduction to the use of the logic trainer kits in the laboratory and the construction of truth tables for simple logic gates.

PART 1: Construct the following four circuits (one at a time) and fill in a truth table by observing if the light emitting diode LED is on or off for all combinations of the single-pole double-throw (SPDT) switches that are connected to the supply voltage and the ground. Once you have all four truth tables filled out, show them to the lab instructor and demonstrate one of the circuits. If you are successful, the instructor will initial below.

The SPDT switches are connected to the supply voltage and ground internally on your logic trainer, so you only have to connect wire between the other side of the switch and the logic gate input. They are very useful for serving as inputs to a circuit you are building. The LEDs are also built into the logic trainer kits and the current-limiting resistor is already connected internally, so you don't have to worry about connecting it. The LEDs are very useful for observing the output of a digital logic circuit.

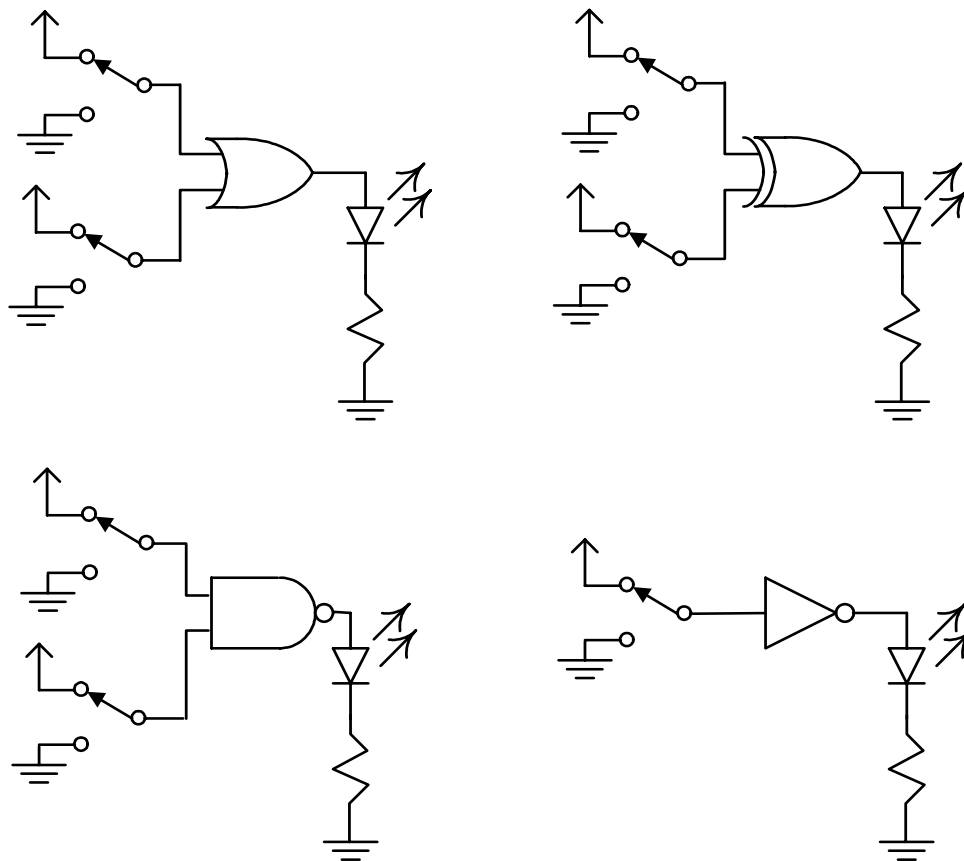

LAB INSTRUCTOR'S INITIALS: _____

PART 2: Design and construct a circuit that realizes the exclusive-OR (XOR) function but uses only 2-input NAND gates from a 7400. You should DRAW the schematic for this circuit BEFORE you attend your laboratory class. As soon as you enter the class, the instructor will check to see if you have this schematic drawn and will initial below for you to receive your pre-lab credit.

The laboratory class time is intended for you to construct and debug your circuits. The DESIGN should occur BEFORE attending the laboratory class, otherwise you won't have time for debugging. This is the reason pre-labs are required.

PRE-LAB: LAB INSTRUCTOR'S INITIALS: _____

Next build your circuit and record the truth table as you did above, then demonstrate it to the instructor. If the circuit functioned properly, the lab instructor will initial below.

LAB INSTRUCTOR'S INITIALS: _____